

ITEM NO.	QUANTITY	PART NUMBER	PART NAME
1	1	30.115.0	BLEEDER VALVE, PANEL MOUNT, 1/4" NPT, 90°
2	1	04.205.0	PANEL NUT, 1.4" NPT BLEEDER VALVE
3	1	19.037.1	KNOB, 1/4 TURN SNUBBER, SMALL
4	1	04.206.0	SCREW, ROUND HEAD, M3-.5MM X 12 LG, SST
5	1	04.207.0	WASHER, M3 SPLIT LOCK WASHER, SST
6	1	04.208.0	PANEL ADHESIVE, 1/4" BLEEDER VALVE

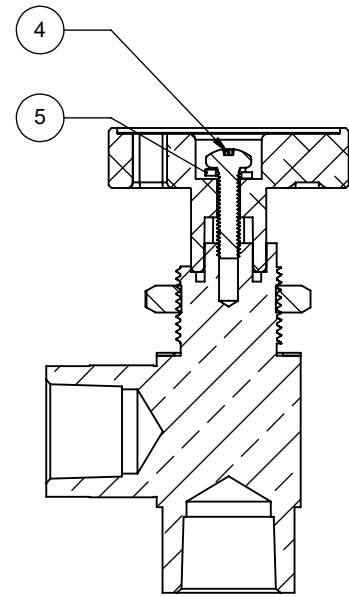

SECTION A-A

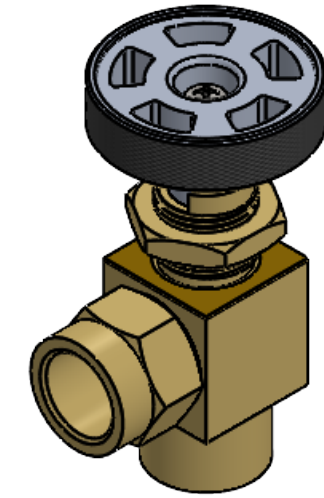
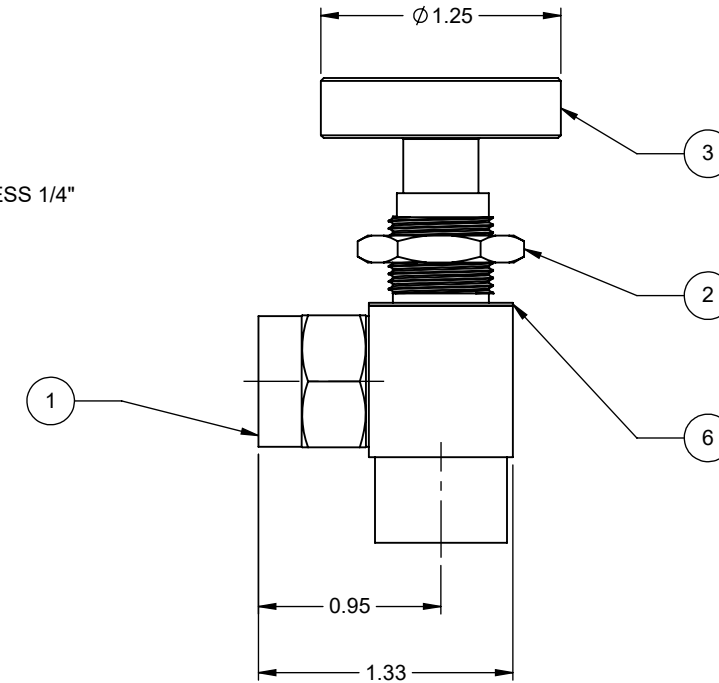
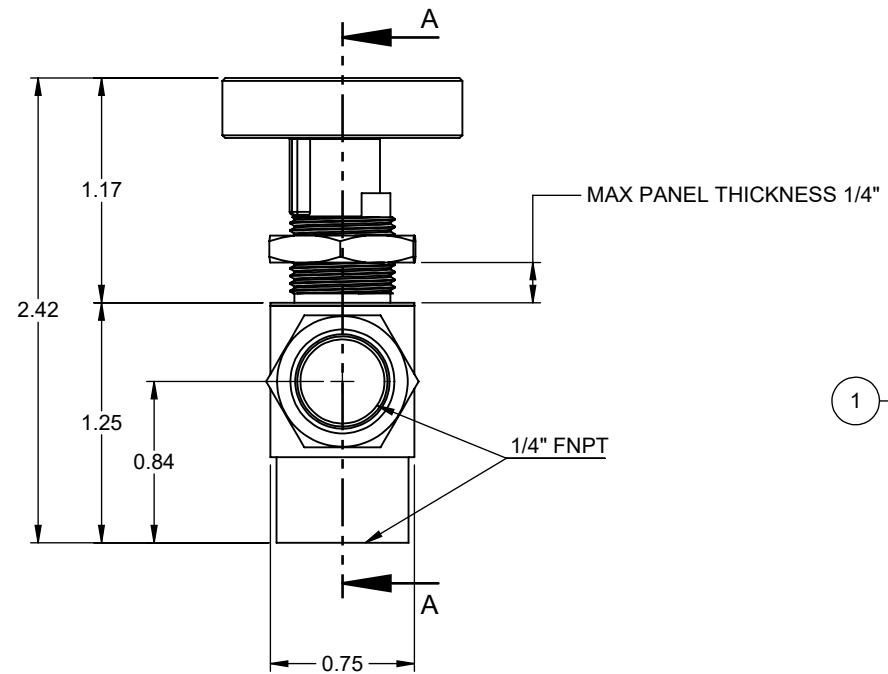

NOTES:
1. MAX PRESSURE 1500 PSI

REMOVE ALL SHARP EDGES ALL DIMENSIONS ARE INCHES STANDARD TOLERANCES: .XX +/- .015 .XXX +/- .005 ANGLES +/- .5°	DRAWN NC	DATE 12/16/2022	TRIDENT EMERGENCY PRODUCTS, LLC <i>"Tomorrow's Ideas Delivered Today"</i>			
	CHECKED		BLEEDER VALVE ASSY, PANEL MOUNT, 1/4" NPT, 90°, WITH KNOB			
	QA		SIZE B	FSCM NO.	DWG NO. 30.115.1	REV
	MFG		SCALE 1:1	SHEET 1 of 1		
OR USED TO MAKE OTHER DRAWINGS OR MACHINERY	APPROVED					