

# TRIDENT

EMERGENCY PRODUCTS, LLC

## Hosemate™



Hosemate™ Part #01.194.0

An innovative inline device designed to avoid twists in supply and discharge hose lines. Enhances fireground safety by allowing water to flow freely to the fire pump and nozzle when included on your intake and discharge hose lines.

### Practical Applications

- Auxiliary intake connections
- Direct Tank fill
- Discharge hand lines
- Eliminate the twisting or “pig tailing” on tender and pumper supply lines using 2-1/2” or 3” hose
- Great for high-rise operations at FD connection or interior standpipe connection
- Perfect addition to ground monitors eliminating hose twists to monitor connections

## Product Features

- Constructed of aircraft grade aluminum
- Hard coated, grey aluminum finish
- Hydrostatically pressure tested up to 750psi
- Double raceway, full-time swivel
  - Water/fluid never touches the swivel
- Equalizer™ pressure relieving threads
- Rocker lug configuration
- Rubber gasket sealing face on female threaded end
- Available in 2.5" FNH x 2.5" MNH size (additional sizes available soon)
- Available in NH threads (special threads available soon)
- NFPA compliant
- Weighs 25.6 ounces

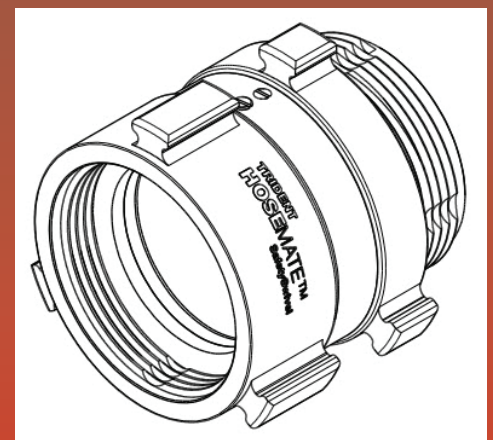
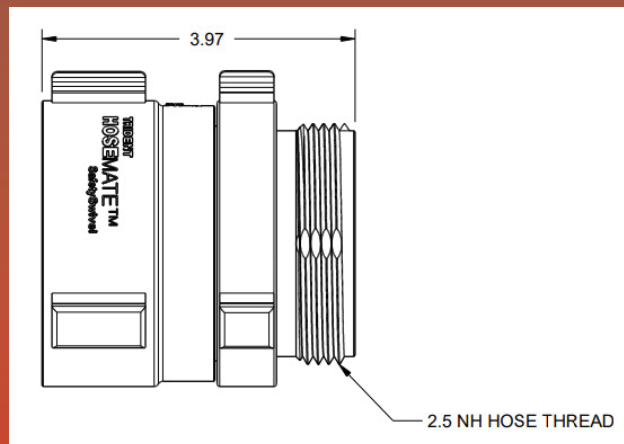
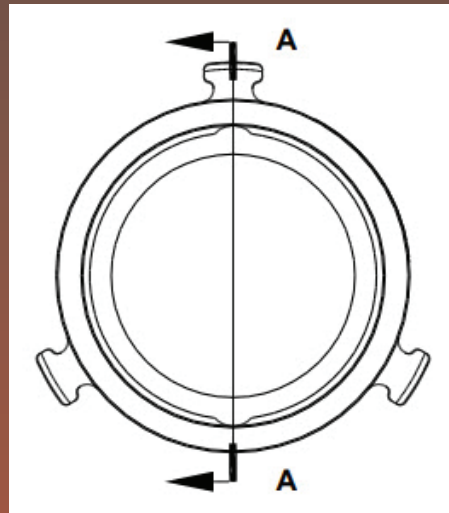
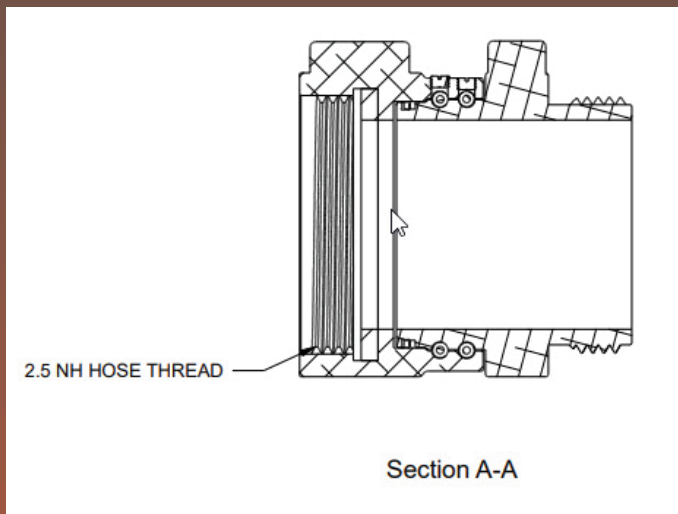

## Trident Emergency Products, LLC

2950 Turnpike Drive, Suite #21 | Hatboro, PA 19040

Phone 215-293-0700

Fax 215-293-0701

Email [sales@tridentdirect.com](mailto:sales@tridentdirect.com)

[www.tridentdirect.com](http://www.tridentdirect.com)



World Class  
Fire Industry  
Products