

REVISIONS				
ZONE	REV	DESCRIPTION	DATE	APPROVED

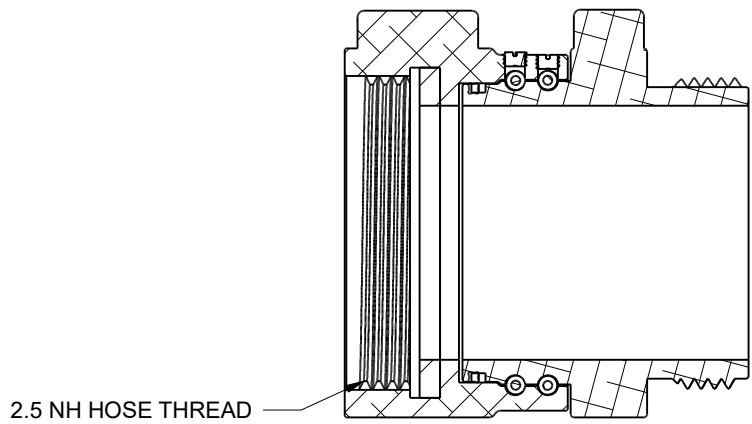

Section A-A

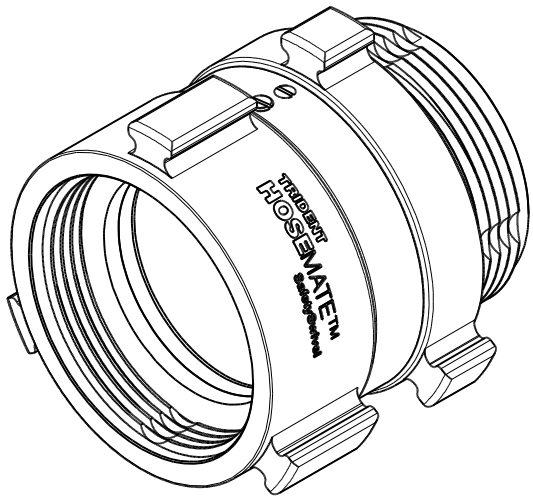
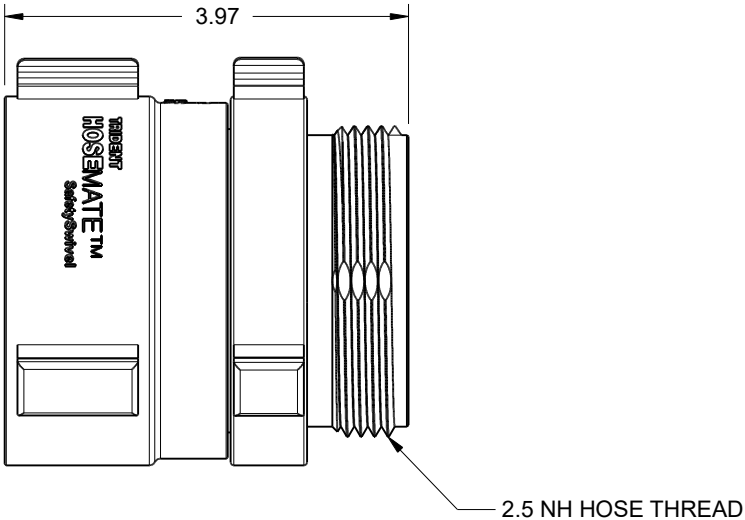
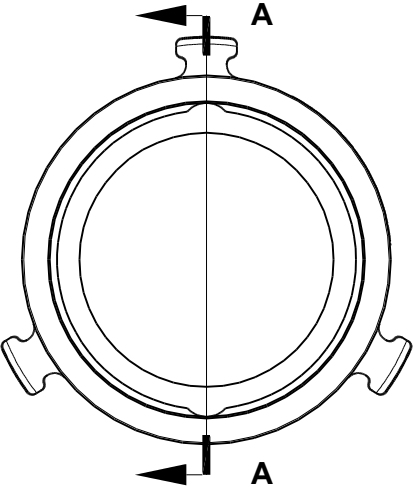

- NOTES:  
 1) HARD COAT ANODIZE PER MIL-A-8625 (LATEST REV)  
 TYPE III, CLASS 2 GREY, 1.0 MIL COATING THICKNESS OR EQUIV.  
 2) MATERIAL: 6061-T6 ALUMINUM  
 3) HYDROSTATIC TEST PRESSURE - 750PSI

REMOVE ALL SHARP EDGES ALL DIMENSIONS ARE INCHES STANDARD TOLERANCES: .XX +/- .015 .XXX +/- .005 ANGLES +/- .5°		DRAWN NC	DATE 05/06/2021	<b>TRIDENT EMERGENCY PRODUCTS, LLC</b> <i>"Tomorrow's Ideas Delivered Today"</i>			
COPYRIGHT © DRAWING NOT TO BE REPRODUCED OR USED TO MAKE OTHER DRAWINGS OR MACHINERY		CHECKED MS	05/06/2021			<b>HOSEMATE HOSE STRAIGHTENER, 2.5 NH</b>	
		QA		SIZE <b>B</b>	FSCM NO.		
		MFG		SCALE 1:2	SHEET 1 OF 1		
		APPROVED					