

REVISIONS				
REV	DESCRIPTION	DATE	DRAWN BY	APPROVED

2.5" NPT  
ADAPTER 01.154.7

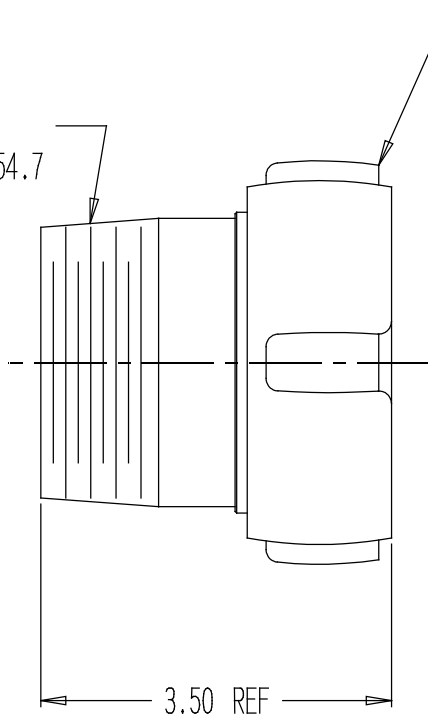

2.5NH SWIVEL  
18.006.0  
2.5" STRAINER  
21.001.5

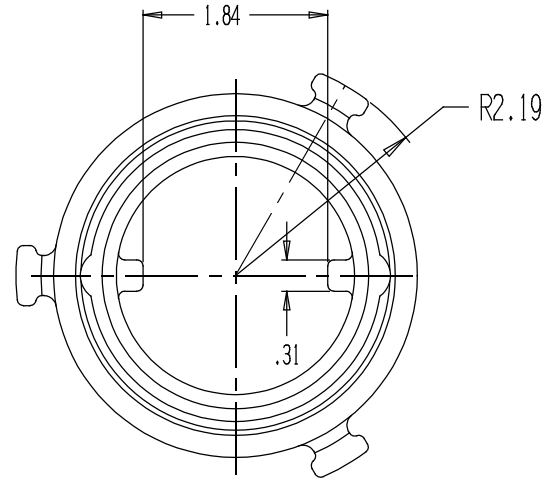

## 2.5" NPT X 2.5" NH ADAPTER

REPORT ERRORS & CHANGES  
REMOVE ALL SHARP EDGES  
UNLESS OTHERWISE SPECIFIED  
ALL DIMENSIONS ARE IN INCHES

STANDARD TOLERANCES:

DECIMALS	ANGLES
.XX ± .030	± 1/2°
.XXX ± .015	

COPYRIGHT ©  
DRAWING NOT TO BE REPRODUCED OR USED TO  
MAKE OTHER DRAWINGS OR MACHINERY

SIZE  
A

DWG  
NO.

01.154.5PC

REV

DRAWN BY MS  
CHECKED BY MS

DATE 08/10/2011

SCALE: NONE

SHEET 1 OF 1