

GP Series™ Foam Pumps

Technical Manual

GP500 Models

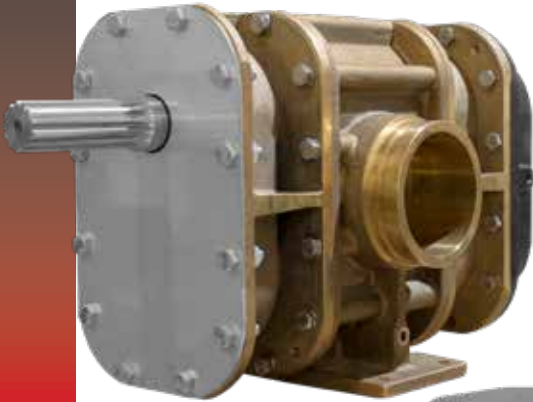

Model U
Universal Mount

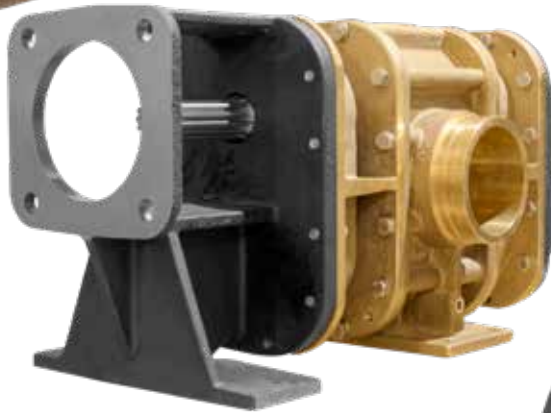

Model H
Hydraulic Mount



Model M
Bell Housing Mount

World Class Fire Industry Products



Contents

GP Series™ - Features and Benefits3

GP500 Rating Chart4

GP 500 Noise Level Information.....4

GP Series™ - Drive Configurations.....5

GP500 Part Number Configuration and Rating.....6

Specifying a GP Series™ Foam Pump Based on Power Source.....7

GP Series™ - Foam Pump Drive Options.....8

Installation Notes.....8

GP500 Performance Curves.....9

Cautions—Warnings—Dangers.....10

Installer Responsibilities.....11

Installer Responsibilities – Pump Orientation.....12

Installer Responsibilities (Continued)13

Repairing The Foam Pump.....14

Pump Disassembly.....14

Pump Disassembly (Continued)15

Pump Assembly - Rebuilding the Foam Pump.....16

Pump Assembly (Continued).....17

Pump Assembly (Continued).....18

Repair Kits and Special Tools.....18

Troubleshooting Guide19

Relief Valve Information.....19

Periodic Pump Inspection and Maintenance20

GP500 Universal Mount Dimension Information21

GP500 Hydraulic Mount Dimension Information.....22

GP500 Bell Housing Mount Dimension Information.....23

Required Repair Tools24

Maintenance History25

Comments and Notes26

Warranty and Product Information27

Repair/Replacement Parts28

GP Series™ - Features and Benefits

Design Features

GP Series High Performance Rotary Gear Foam Pumps are loaded with a Wide Range of New Design Features. It is Self Priming and can pump Multiple Viscosities of Foam or Water. This versatile design is suitable for Electric, PTO, Diesel/Gasoline Engine, Water Driven or Hydraulic drive motors. Specific features are listed below.

Why GP Series™ Foam Pumps Include Timing Gears...

- ▶ Timing Gears Synchronize the Two Pumping Rotors
- ▶ Timing Gears Allow for DRY Running Without Damage
- ▶ No Rotor Contact Allows for Pumping Foam or Water
- ▶ Water Can Be Used for: Calibration, Testing and Training

GP500 Models

- ▶ Brass Housing with Bronze Alloy Rotors
- ▶ 17-4PH (Precipitation Hardening) Stainless Steel Shafts
- ▶ Double Row Spherical Roller Bearings - Sealed for Life
- ▶ Splash Oil Lubrication for Timing Gears
- ▶ Pump Mounts in any Orientation
- ▶ Victaulic™ Suction/Discharge Connections
- ▶ Splined Pump Drive Shaft
- ▶ Silicon Carbide Mechanical Seals
- ▶ Shaft is 100% Sealed from Pumping Medium
- ▶ Rubber Seals - No Gaskets
- ▶ Stainless Steel Fasteners
- ▶ Designed for Easy Serviceability
- ▶ Optional SAE Hydraulic Motor Mounting Bracket
- ▶ Optional SAE 2/3 Bell Housing Motor Adapter
- ▶ Optional Speed Sensor



Timing Gears and Sealed 2 Row Roller Bearings



Victaulic™ Inlet and Outlet Connections



17-4PH Stainless Shafts Bronze Pump Rotors

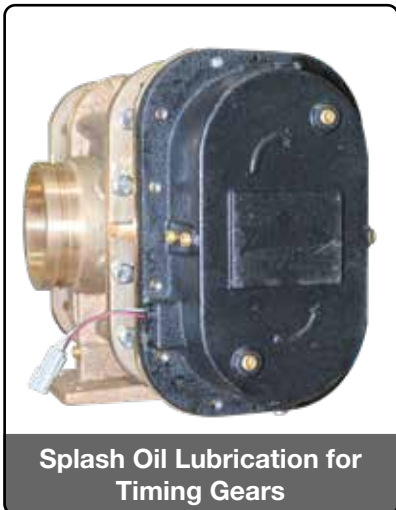

Splash Oil Lubrication for Timing Gears

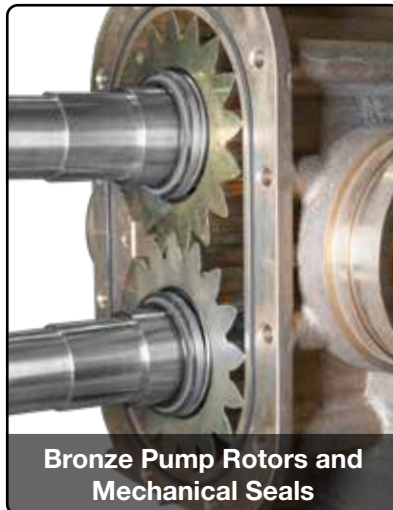

Bronze Pump Rotors and Mechanical Seals



Rubber Seals and Stainless Steel Fasteners

GP500 Rating Chart

Foam Pump Rating Chart

Foam Pump		1000-RPM						1200-RPM						1500-RPM						1600-RPM						
MODEL	PRESSURE	FLOW		POWER		TORQUE		FLOW		POWER		TORQUE		FLOW		POWER		TORQUE		FLOW		POWER		TORQUE		
	PSIG BAR	GPM	LPM	HP	Kw	LB-FT	Nm	GPM	LPM	HP	Kw	LB-FT	Nm	GPM	LPM	HP	Kw	LB-FT	Nm	GPM	LPM	HP	Kw	LB-FT	Nm	
GP500	50	3.4	345	1306	34	25	179	242	415	1571	52	39	228	309	520	1968	75	56	263	356	545	2063	84	63	294	399
	100	6.9	330	1249	44	33	231	313	400	1514	64	48	280	380	510	1931	92	69	322	437	535	2025	96	72	336	456
	150	10.3	315	1192	55	41	289	392	385	1457	76	57	333	451	500	1893	106	79	371	503	520	1968	112	84	392	532
	200	13.8	300	1136	66	49	347	470	365	1382	90	67	394	534	485	1836	124	92	434	589	505	1912	128	95	448	608
	250	17.2	280	1060	80	60	420	570	355	1344	104	78	455	617	470	1779	144	107	504	684	490	1855	148	110	518	703
	300	20.7	265	1003	96	72	504	684	340	1287	120	89	525	712	450	1703	168	125	588	798	475	1798	170	127	595	807

NOTE: Power numbers (HP/Kw) listed above are the net power requirements. Pump installer must evaluate the drive system for power losses and compensate to meet the pump power requirements.

Refer to Pages 21-23 for additional pump dimension details.

GP 500 Noise Level Information

The Trident GP500 positive displacement, rotary gear foam pump (500 GPM capacity) is a large sized, large capacity foam pump designed for use with high capacity water pumps utilizing a foam concentrate proportioning system, and for use on high capacity foam concentrate nurse tankers. Up until now, a 300 GPM foam pump of this design was the primary foam pump used on these types of apparatus. The GP500 pump is some 60% larger in capacity and physical size, and over twice the weight of 300 GPM pumps. With larger pump size and capacity come increased noise levels with readings exceeding 100dB at 1-meter. These higher noise levels are due to several factors:

1. Increased size of rotating components within the pump, i.e. rotors, shafts, bearings, timing gears.
2. Increased volumes of liquid passing through the pump. As pump speeds and operating pressures increase, so will noise levels. Viscosity of pumping liquid also affect noise levels; pumping water will create higher noise levels than foam concentrates.
3. As the foam pump capacity increases, so do required power requirements. Increased size of the pump's driving system will create increased noise levels.
4. Inadequate pump mounting structure can cause vibrations, increasing noise levels by transmitting sounds into other chassis components. Most apparatus have large sheet metal enclosures that can resonant sound and amplify noise levels.

There are a few areas to carefully review when installing large capacity foam pumps:

1. The GP500 pump weighs approximately 480 pounds (220 kg), and if the pump is driven by a hydraulic motor, this can add an additional 150 pounds (70 kg) to the overall assembly. The pump and driver mounting structure must be designed with sufficient strength to prevent flexing and creating additional vibration.
2. PTO driven pumps must be carefully reviewed in respects to drive shaft alignment, balance, shaft length and size, and foam pump mounting location relative to PTO location to match transmitted horsepower and speed. Critical and half-critical shaft speeds, along with joint operating angles, angle cancellation, and joint phasing must be reviewed. Improper engineering review of a PTO application can result in dangerous drive shaft operation, damage to the foam pump and PTO, and create harmonic vibrations and excessive noise levels.
3. Where possible, sound dampening material can be applied to nearby surfaces to assist in mediating some of the noise level. Consider surrounding the pump in a separate enclosure.
4. Piping connections to and from the pump should utilize flexible type connectors and piping supports to assist in minimizing and transmitting noise.
5. The use of shaft couplings with a non-metallic, resilient inserts and exacting alignment can assist in noise reduction. Carefully follow coupling manufacturer's instructions for coupling alignment.

Trident Emergency Products recommends that all personnel in close proximity to rotating gear pumps and equipment follow necessary precautions to minimize the effects of the ambient noise levels by wearing proper hearing protection devices.



WARNING

ALWAYS OBSERVE PROPER PRECAUTIONS WHEN OPERATING PUMPS OR ANY MACHINERY. PERSONAL PROTECTION EQUIPMENT MUST ALWAYS BE PROVIDED AND UTILIZED.

GP Series™ - Drive Configurations

Typical Power Sources

The following diagrams depict some of the normal methods of powering the GP500 Foam Pump.

The Drive methods are as follows:

Model M: Engine Bell Housing Adapter

Model H: Hydraulic Motor Adapter

Model U: Universal; PTO/Electric/Engine Mount/Water Motor

In most cases the power supply shaft is connected to the pump drive shaft with a flexible drive coupling or equivalent. **NOTE:** Pump installer is responsible for providing the proper drive coupling. See Installer Responsibilities on Pages 11-13.

Contact Trident for coupling recommendations.

The exception would be a PTO driven installation which utilizes standard universal joints.

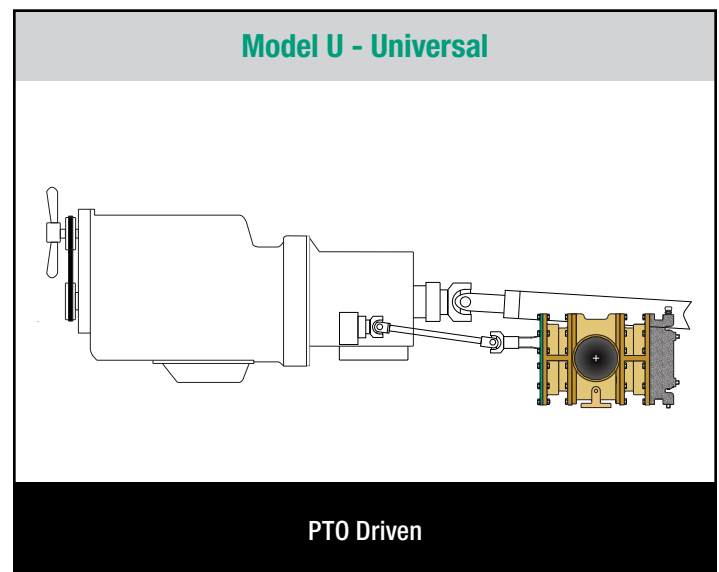
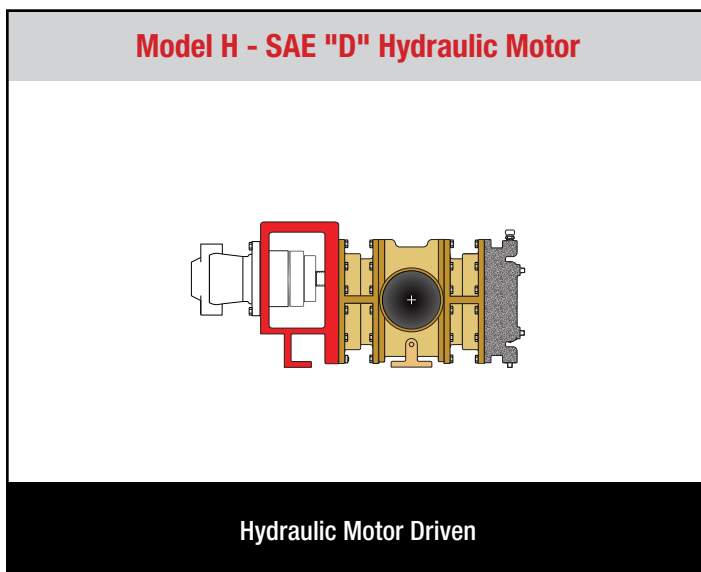
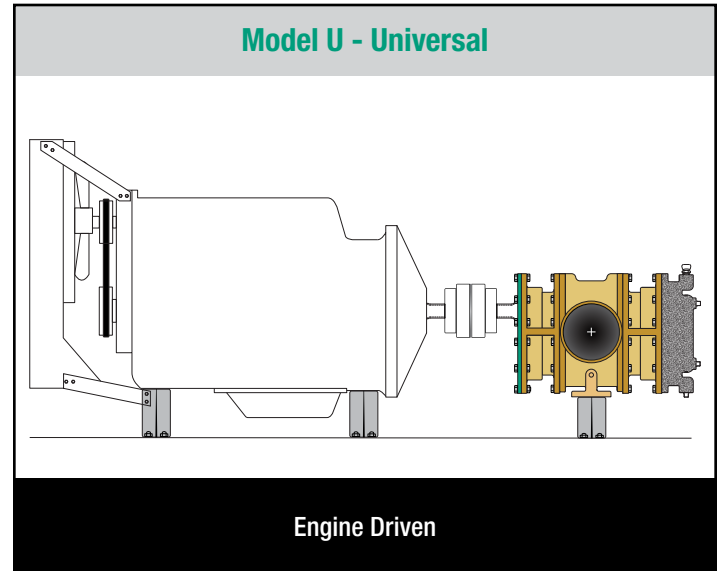
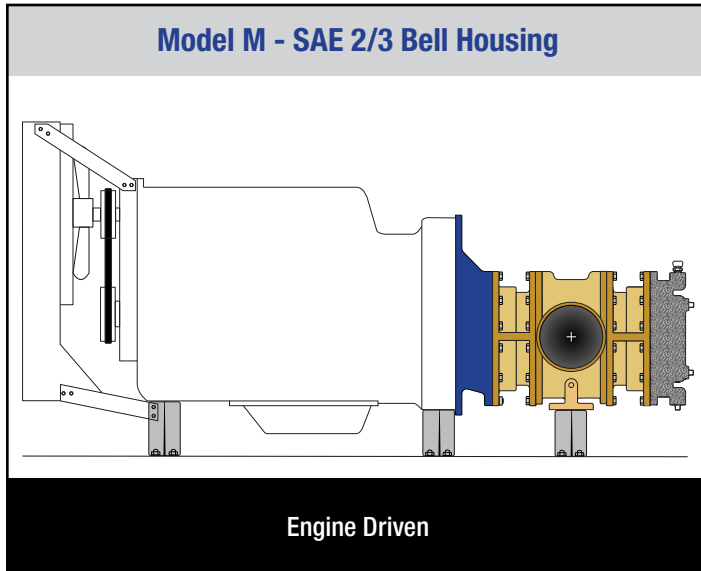
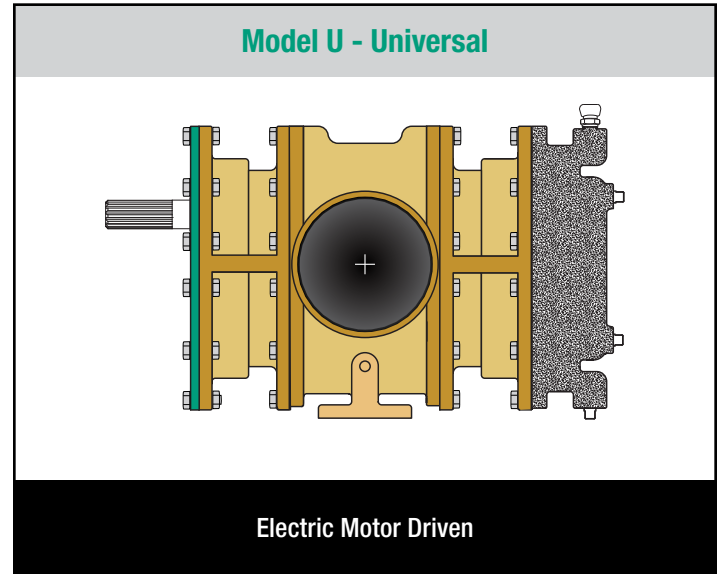

GP500 Part Number Configuration and Rating

Pump Configurations

Standard Flow Direction										
MODEL	Driving Shaft	Nominal Flow		Max Pressure		Pump In/Out	Drive/Connection	Pump Weight		Trident Part #
		GPM	LPM	PSIG	BAR			Pounds	Kg.	
GP500U-T	Top RH	500	1893	300	20.7	5" VIC	Universal Drive	430	195	31.022.2
GP500U-B	Bottom LH	500	1893	300	20.7	5" VIC	Universal Drive	430	195	31.022.4
GP500H-T	Top RH	500	1893	300	20.7	5" VIC	Hydraulic Motor SAE D, 2/4-Bolt	480	218	31.022.0
GP500M-T	Top RH	500	1893	300	20.7	5" VIC	Engine Bell Housing	495	225	31.022.3

Reverse Flow Direction

Reverse Flow Direction										
MODEL	Driving Shaft	Nominal Flow		Max Pressure		Pump In/Out	Drive/Connection	Pump Weight		Trident Part #
		GPM	LPM	PSIG	BAR			Pounds	Kg.	
GP500U-RT	Top LH	500	1893	300	20.7	5" VIC	Universal Drive	430	195	31.022.12
GP500U-RB	Bottom RH	500	1893	300	20.7	5" VIC	Universal Drive	430	195	31.022.14
GP500H-RT	Top LH	500	1893	300	20.7	5" VIC	Hydraulic Motor SAE D, 2/4-Bolt	480	218	31.022.10
GP500M-RT	Top LH	500	1893	300	20.7	5" VIC	Engine Bell Housing	495	225	31.022.13

Specifying a GP Series™ Foam Pump Based on Power Source

How Will the Pump be Powered

Standard Flow Direction

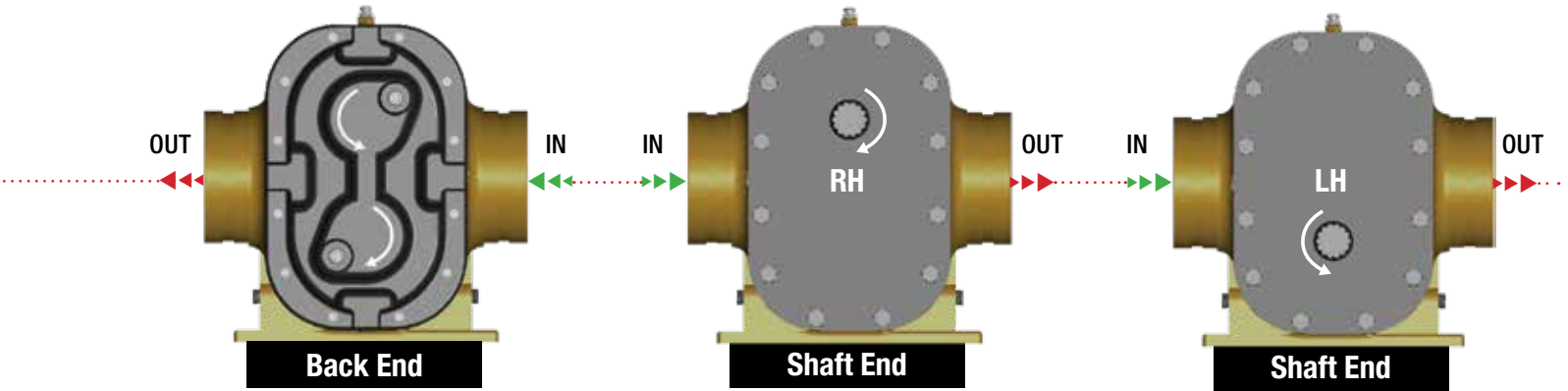

Reverse Flow Direction

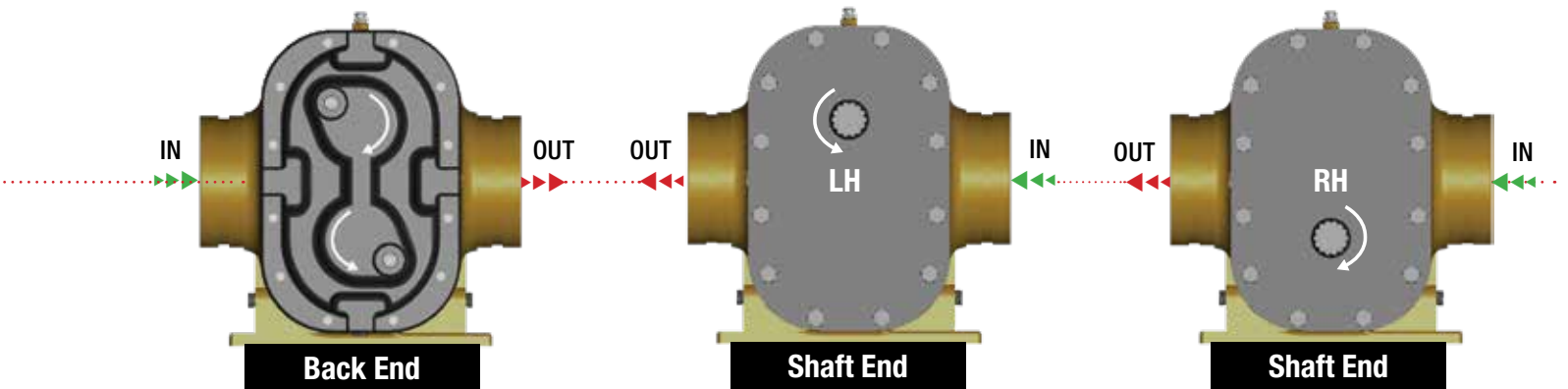

GP500 Performance Curves

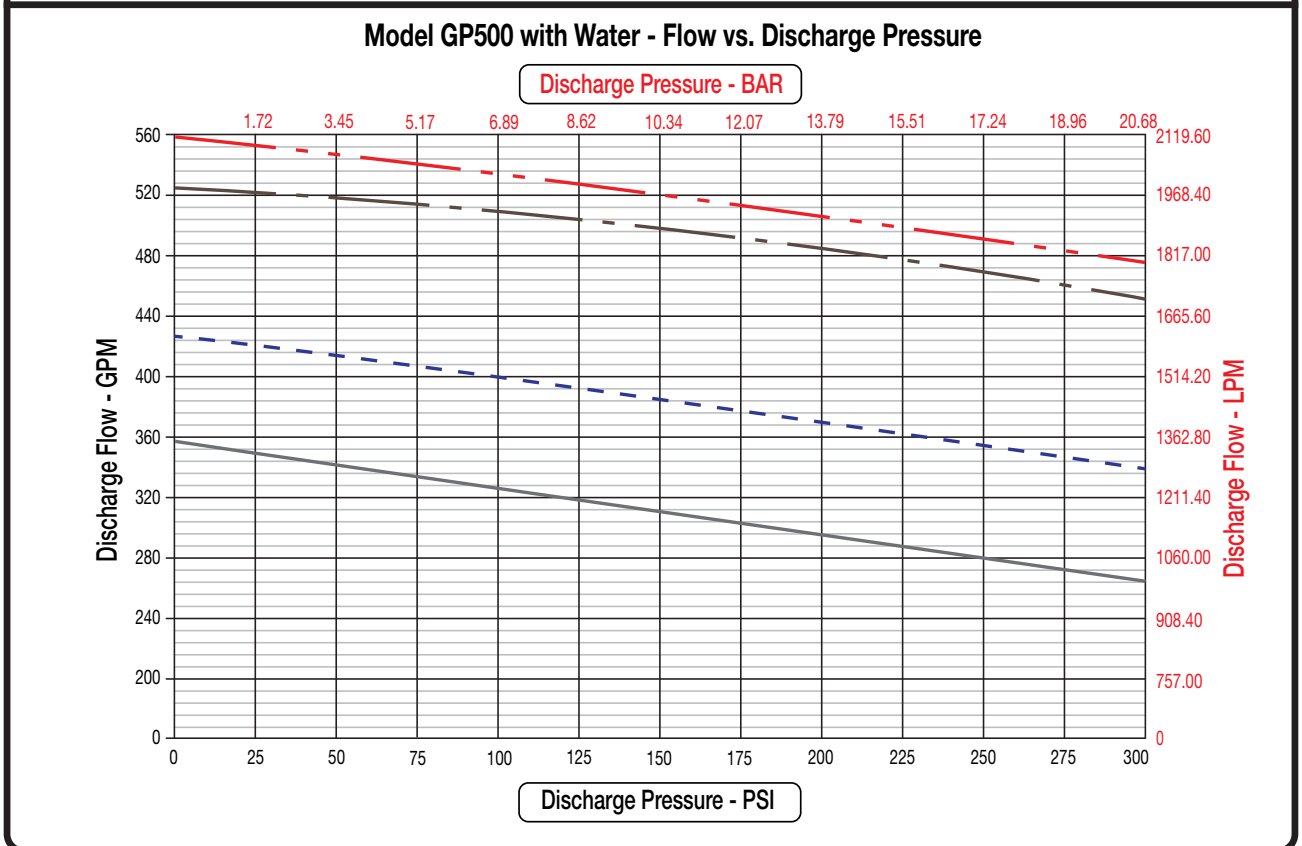
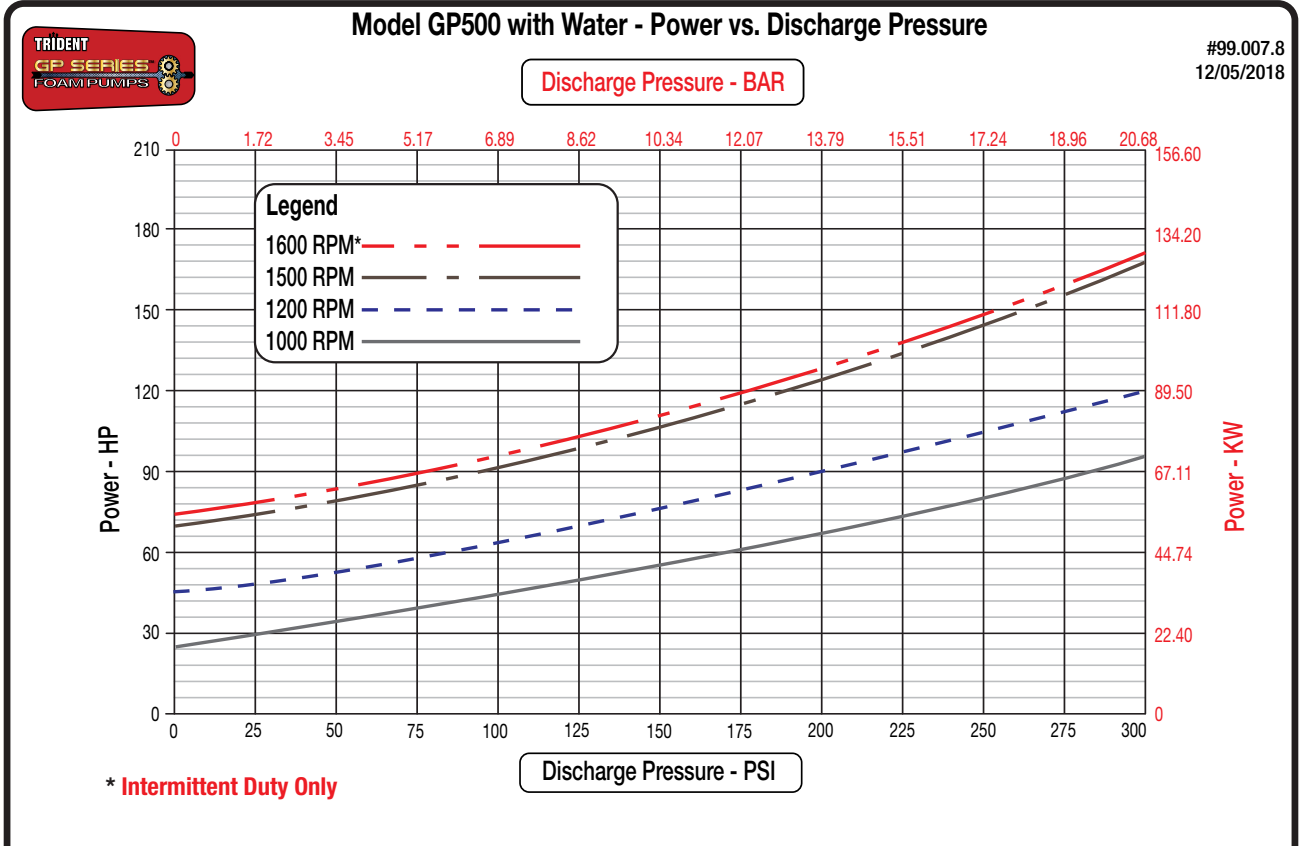

Cautions—Warnings—Dangers

The following special information is safety related and intended to advise operators and service technicians of potential hazardous situations involving the operation, maintenance and repair of rotary gear pumps. All personnel involved with operation or repairs of rotary gear pumps must be properly qualified and must read and understand all of the enclosed safety, installation and repair instructions contained within this manual prior to operation and/or repairs.

CAUTION

CAUTIONS are used to indicate a hazardous situation that, if not avoided, could result in minor or moderate injury. Property damage could also be a result, if the hazardous situation is not avoided.

WARNING

WARNINGS are used to indicate a hazardous situation that, if not avoided, could result in death or serious injury. Property damage could also be a result, if the hazardous situation is not avoided.

DANGER

DANGERS are used to indicate a hazardous situation that, if not avoided, will result in death or serious injury. Property damage will also be a result, if the hazardous situation is not avoided.

CAUTION

1. Do not operate a rotary gear pump dry for more than ten (10) minutes.
2. Operating rotary gear pumps can create heat and pumps should never be allowed to operate in a “dead headed” condition – ensure all suction and discharge valves in the system are open prior to starting the pump.
3. Close all pump isolation valves and drain the pump prior to removal from the system.
4. Routine inspection and maintenance must be performed as outlined in this manual.
5. Only use lubricants and cleaning solvents listed in this manual for maintenance and repairs. Observe correct material handling procedures when working with lubricants and solvents.

WARNING

1. Proper Ear Protection must be worn while operating rotary gear pumps.
2. Proper Eye Protection is required while operating and maintaining a pump.
3. Rotary gear pump installations require that personnel be properly trained.
4. Rotary gear pump repairs must be performed by properly trained personnel.
5. De-pressurize the pump and plumbing prior to removal of any piping connections.
6. Pump maintenance and repair service should be performed in a clean environment and only utilize tools designed for the procedures.
7. Use only parts approved by Trident Emergency Products when making repairs to this pump. See [Pages 18 and 28](#) for a list of parts and repair kits available.

DANGER

1. Do not operate the pump at pressures exceeding the maximum listed operating pressure of 300 PSI [20.7 BAR].
2. Only utilize components with the proper pressure rating and properly sized drive components when installing the pump.
3. Always disconnect the power source to the pump prior to doing any maintenance or performing any pump repairs. Rotating drive components can cause serious bodily injury and damage to surrounding equipment. Observe and perform **Lock-Out / Tag-Out Procedures**.
4. Use a safety relief valve or other type of pressure limiting device/system to prevent over-pressurization of the pump and piping. If a safety relief valve is installed in the pumping system, do not adjust to a “set pressure” exceeding 110% of the maximum pump listed working pressure.

Installer Responsibilities

Unpacking and Inspection



CAUTION

Rotary gear pumps are heavy and installation personnel should use equipment with proper weight rating for lifting pumps. Personal Protective Equipment should be utilized when handling heavy loads.

1. All GP Series rotary gear pumps are suitably packaged to prevent damage during transit with normal handling. Thoroughly inspect shipment immediately upon arrival:
 - a. Inspect crate and packaging for signs of damage caused during shipping and note this on the bill of lading. Trident Emergency Products is not liable for damages incurred during shipping. Photos of damage are suggested.
 - b. Check for shipment shortages against the bill of lading, and note any discrepancies on the bill of lading. Trident Emergency Products is not liable for shortages incurred during shipping.
 - c. Notify Trident of damages to contents or shortages that are not a fault of the carrier.
 - d. Protect pump from any foreign material entering the pump body. Do not remove the protective port caps until piping connections are ready to be made.
 - e. If pump is not to be immediately installed, leave the pump secured in original packing crate and store in a clean, dry location.
2. All GP Series rotary gear pumps are assembled at the factory to a specific shaft rotation for correct porting. Upon receipt, check pump tag for correct pump rotation markings. The pump rotation is not interchangeable and is not field changeable. Pages 6 and 7 illustrate pump shaft rotation.

Pump Installation

1. All GP Series rotary gear pumps are shipped **WITHOUT** oil for the timing gears. Installer is required to fill timing gear case reservoir with the correct amount of oil based on the pump mounting position before any pump operation. See Page 12 of this manual for various acceptable mounting positions and associated oil level check plug location. Fill with a high quality SAE 30W (ISO Grade 100) conventional or synthetic oil. Failure to fill with appropriate amount of oil will damage the pump and void the warranty.



CAUTION

Do not operate pump without checking for proper oil level and do not over fill timing gear case with oil.

2. All GP Series rotary gear pumps are shipped with the same standard configuration of plugs, oil fill and magnetic drain plug placement, as shown on Page 12 of this manual. The pump can be mounted in any of the positions shown. If pump is mounted in any position other than standard, the plugs, oil fill and magnetic drain plug must be re-positioned to match illustrations shown on Page 12.
3. Fasteners used to secure the pump to its mounting base must be ½" [12.7mm] diameter, Grade 8 of proper length with lock washers and nuts or Nylock nuts torqued to 100-110 foot-pounds. Use of a thread locking compound (Loctite®) is recommended.

Piping Connections

1. Suction pipe size is 5" minimum, or 6" maximum for the 5" pump suction port, particularly for viscous liquids. Optimize suction conditions by mounting the pump below liquid tank level (flooded head condition), keeping pipe runs as straight and short as possible, limiting the number of pipe elbows and going around obstacles rather than over – do not create air pockets. Where possible, 45° or 90° fittings should not be used at the pump suction and discharge ports. It is critical that all piping connections are air tight.
2. Discharge piping should be suitably sized to create the required downstream system pressure.
3. A strainer on the suction side of the pump is required to prevent foreign matter from entering the pump causing pump seizure or damage to pump rotors that will impede performance. Strainer must be of sufficient size to prevent excessive vacuum conditions and impede liquid flow into the pump resulting in cavitation. The strainer must have a simple means for cleaning and should be checked regularly for blockage – a clogged strainer will cause pump cavitation.
4. All piping connections to the pump must be properly supported - the pump is not designed to carry piping loads. Piping support brackets cannot be attached to the pump. Teflon tape or pipe sealant from threaded connections must not be allowed to enter piping system. All piping connections must be rated for a minimum of 400 PSI [27.5 BAR] working pressure.
5. To protect foreign material from entering the pump body, clean all suction and discharge piping of scale, weld splatter and metal filings prior to connecting pipes to the foam pump.



DANGER

Pump installer is required to install a safety relief valve or other type of pressure limiting device/ system to prevent over-pressurization of the pump and piping. If a safety relief valve is installed in the pumping system, do not adjust to a "set pressure" exceeding 110% of the maximum pump listed working pressure. Trident highly recommends that the discharge side of the relief valve be piped back to the foam storage tank, and not around the pump back to the suction port (unless permitted by the foam system manufacturer).

Installer Responsibilities – Pump Orientation

Pump Rotation for Ease of Piping Installation

The pump can be installed in various orientations to suit your piping needs as shown in **Figure 3** below. **NOTE:** This diagram shows the standard rotation of the pump. Reverse Flow Direction is shown in **Figure 4** below. For other configurations, please contact the factory. The installed orientation affects the location of the following; Oil Level Check, Oil Fill, Oil Vent and Oil Drain. These ports utilize ¼" NPT Pipe Plugs. Refer to **Figures 3 and 4** to alert all operators and maintenance personnel of your specific installation so that proper inspection and maintenance can be performed. **NOTE:** Utilize Teflon Tape or Pipe Sealant on all timing gear cover pipe fittings.

⚠️ WARNING

Pumps are shipped dry, without any oil. A multi language warning label is attached to the fill/vent port of each pump when shipped. Installer is required to fill timing gear case reservoir with the correct amount of oil based on the pump mounting position before any pump operation. Use images below to determine the oil level check plug based on pump mounting position. An initial fill should be checked after pump installation and prior to start-up. Fill with a high quality SAE 30W (ISO Grade 100) conventional or synthetic oil. Failure to fill with appropriate amount of oil will damage the pump and void the warranty.

Standard Flow Direction Diagram:

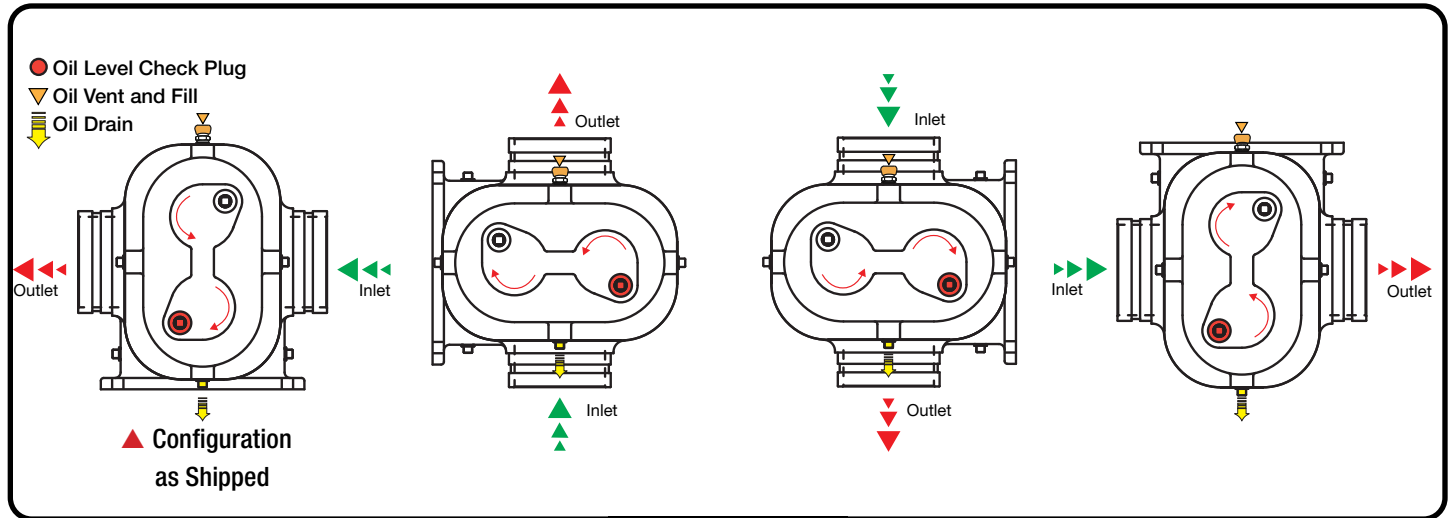

Figure 3

Reverse Flow Direction Diagram:

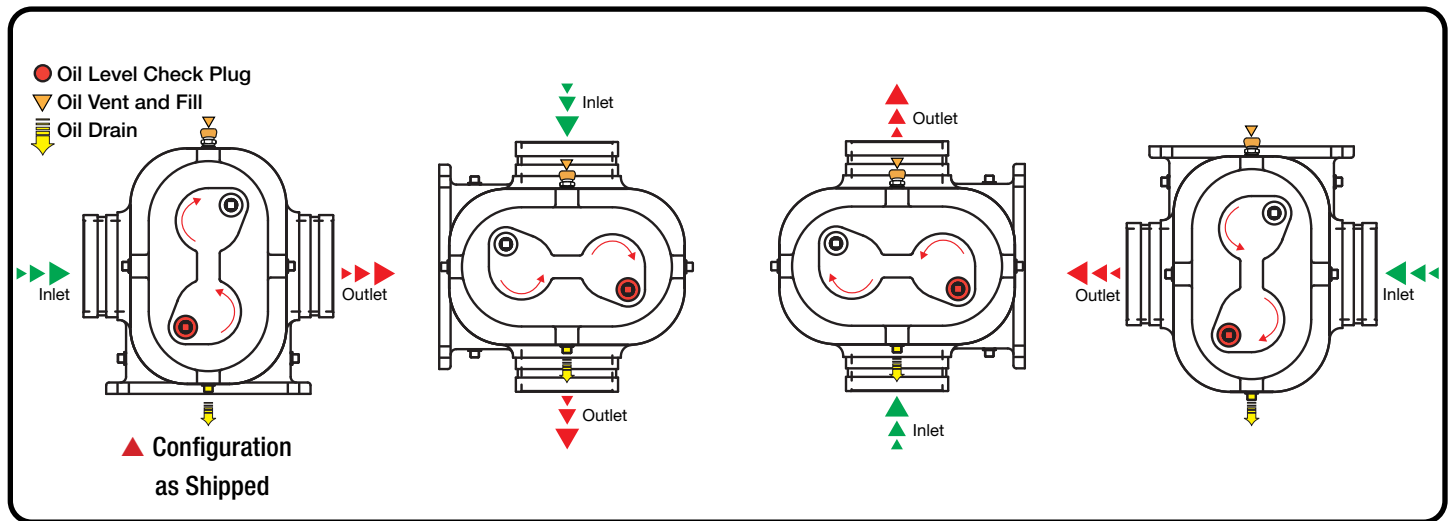

Figure 4

NOTE: The left hand image in **Figures 3 and 4** illustrate the standard factory assembly configuration for the oil level plug, oil fill/vent and magnetic oil drain plug. Pump installer must re-orient these fittings to match final mounting position. Failure to do so will void warranty.

Installer Responsibilities (Continued)

Pump Shaft Coupling

1. Pump installer is required to provide all drive and coupling components to the pump. All drive components and connections must be properly rated for the horsepower and torque required to drive the pump. Coupling and shaft guards should be provided, properly secured and utilized whenever the pump is operating.
2. Proper pump shaft coupling alignment is critical to protect pump seal and bearing life, and the life of the coupling. The shaft coupling is not designed to compensate for angular and parallel misalignment and proper alignment must be checked prior to start-up. Closely refer to the coupling manufacturer's installation and alignment instructions during installation.
3. Misalignment of pump and driver shafts can be angular and/or parallel as shown in figures below. Maximum angular offset in the two coupling halves cannot exceed 1 degree; parallel offset cannot exceed 0.015" [0.4mm]. Loosen mounting bolts of pump and driver, set proper alignment, and re-tighten bolts to proper torque rating provided by coupling manufacturer. See Figure 5 below.
4. Routine inspection of coupling alignment should be performed. Failure of pump seals, bearings, and abnormal pump wear will not be covered by warranty due to improperly installed and aligned shaft coupling.

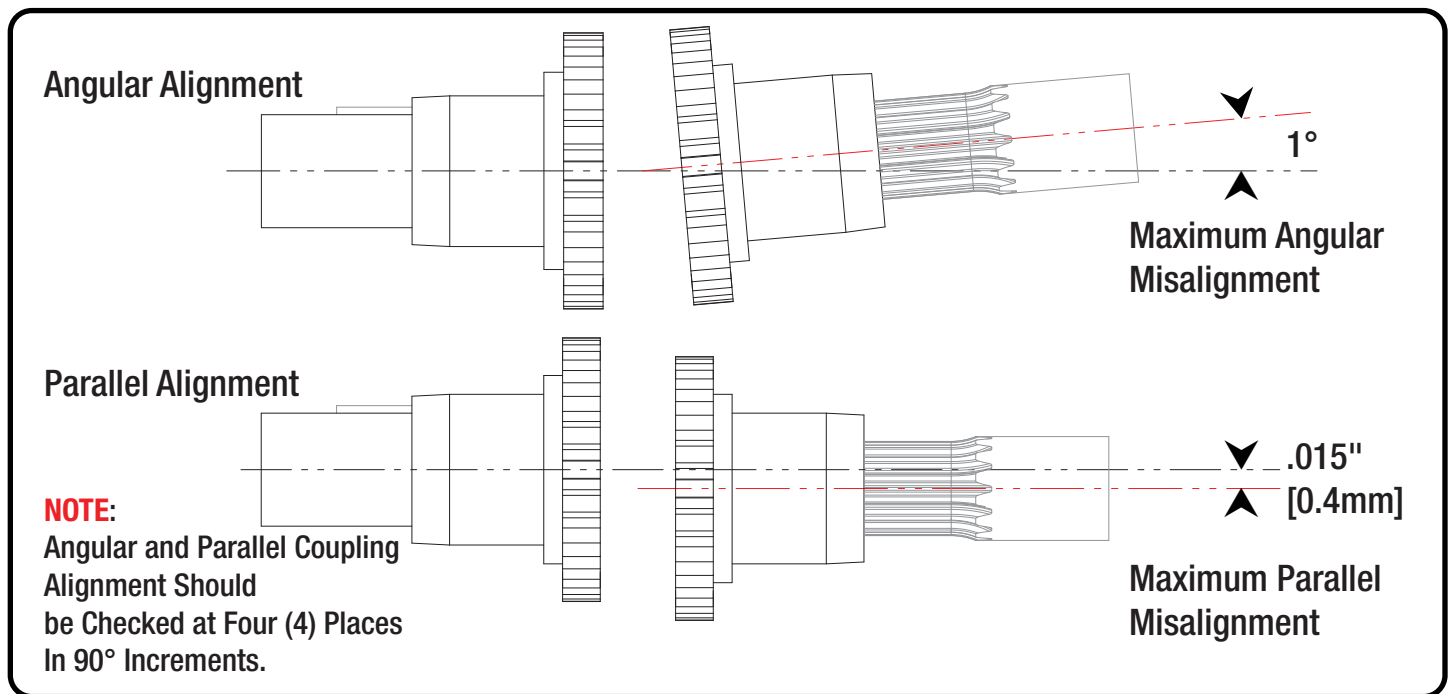

Figure 5

Pre Startup Inspection



Lock-Out/Tag-Out the pump power source until installation is complete and pre-start-up inspections are complete.

1. Check for proper oil level and placement of oil level check, oil fill, oil vent and oil drain. Refer to Figures 3 and 4 on Page 12.
2. Check pump mounting bolts and nuts for proper torque. Refer to Page 11 Pump Installation Item #3.
3. Inspect all drive components and connections for tightness and proper alignment. Verify that all guards are securely in place.
4. Inspect all piping supports. Ensure that the foam pump is not supporting any of the suction/discharge pipes.
5. Flush and leak test all suction and discharge piping.
6. All suction and discharge valves must be fully open. Do not start a pump in a "dead head" condition. Close all drain valves.
7. Verify that pump shaft turns freely and is not bound or seized.
8. Verify the correct rotation of pump power source.
9. During initial system start-up, bump start the foam pump driver to ensure correct pump shaft rotation. Pages 6 and 7 illustrate pump shaft rotation.

Repairing The Foam Pump

Pump repairs should only be carried out by experienced personnel with the proper tools, equipment and facility to perform the work required as outlined in this manual. Failure to perform repairs correctly can result in a pump that operates improperly.

Pump Disassembly

Repairing the Foam Pump

The disassembly procedures listed below will allow for the replacement of the timing gears if they have failed from lack of lubrication, oil or foam seals should a leak occur, roller bearings if they have failed, and complete shaft/rotor assemblies if they have been damaged. Individual replacement parts and repair kits are listed on the **Page 18** of this manual. It is highly recommended that all seals and bearings be replaced when any disassembly beyond the replacement of the timing gears has taken place. Follow the steps listed below and refer to the various photos/diagrams included to disassemble the foam pump. Refer to **Page 24** for required repair tools.

Prior to disassembly, the hydraulic adapter/or bell housing/or cover plate and coupling should be removed from the drive shaft end. Place matching marks on the timing gear cover, pump heads and pump body to assist with the reassembly process.



Only 304 series stainless steel fasteners are used for this foam pump. If fasteners are replaced they must be the same grade, size (including length) and material. Do not reuse previously torqued bolts. A hardware kit is available and listed on Page 18.

Pump Disassembly

1. Remove the 1/4" NPT magnetic drain plug with a 1/4" Allen wrench and drain the oil from timing gear case. See **Photo 111**.
2. Loosen and remove the (12) 1/2" bolts and lock washers that attach the cast iron timing gear cover to the pump head. Separate the cover from the pump head using 1/2" -13TPI bolts in each of the two (2) tapped holes located on opposite corners of the pump head. Refer to **Photo 113** on **Page 14** for the tapped hole location and **Page 18** for details. Remove the O-Ring gasket from the groove in the brass pump head. **NOTE:** Do not reuse any seals or gaskets.



Tool T02

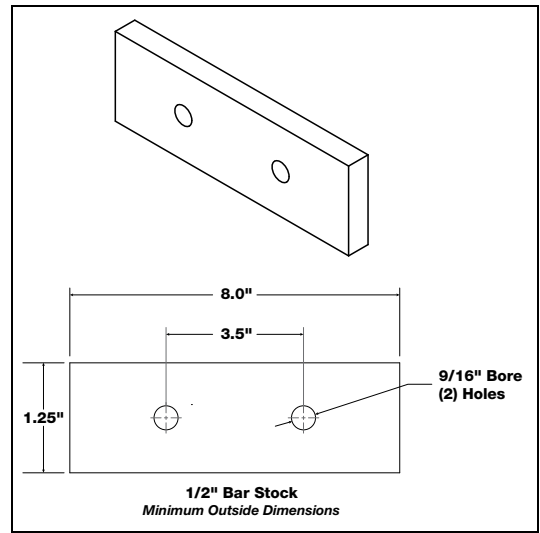

Figure 6

3. Wedge a plastic block, **Tool T17** (3/4" x 4" x 10" block) into the intake or discharge port to keep the rotors/shafts from turning. Then loosen the timing gear locknuts using a 1 7/16" socket **Tool T02**, but leave them on for now to protect the threads at the end of the upper and lower shaft. See **Photo 112**.

4. Fabricate a gear pulling tool **T06** from a steel bar as shown in **Figure 6**. Use (2) 1/2"-13 x 2 1/2" long hex head bolts See **Photo 113** to insert thru the holes in the bar and into the threaded holes provided in the timing gear. Tighten bolts **EVENLY** on the puller bar until they make contact with locknut – *making sure locknut is positioned to protect the shaft threads* See **Photo 114**. Tap with plastic/hard rubber dead blow hammer **Tool T16** to unseat gear from shaft taper. Retightening of the bolts and more tapping with the hammer may be necessary to unseat the gears from the shaft. Repeat this process for both timing gears.



111

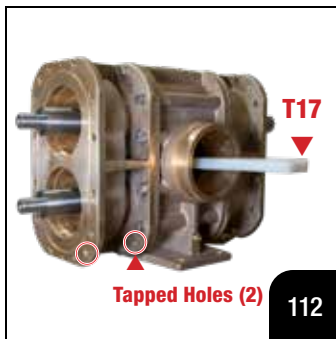

112

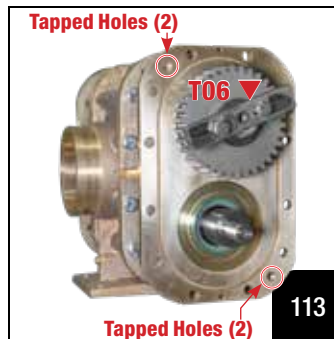

113

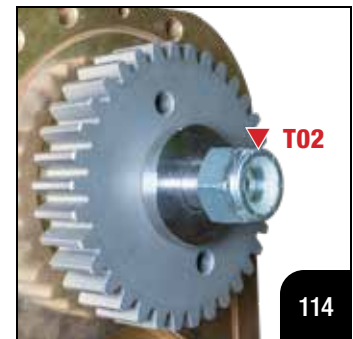

114

Pump Disassembly (Continued)

5. Remove both sets of timing gear locknuts, spacers and timing gears. If the repair was only to replace the gears, stop the disassembly here and refer to the assembly instructions starting on **Page 16**. If the timing gears are to be reused, place a mark indicating the Top Gear and the Bottom Gear to reinstall them in the same manner as they were originally installed. *Otherwise continue to next step.*
6. Remove oil seals from pump head. Remove the Snap Ring using a tool similar to what is shown **Tool T13** on **Page 24**. Next, remove the brass ring that contains the oil seal using two (2) needle nose pliers. Refer to **Photo 115**. Discard the oil seals. **NOTE:** Do not reuse any seals or gaskets. If the repair was only to replace the oil seal, stop the disassembly here and refer to the assembly instructions starting on **Page 16**. *Otherwise continue to next step.*
7. Before disassembly, apply match marks (A-A) (B-B) to the pump body and heads making note of the "S" location on the heads in relation to the body. Remove the twelve (12) bolts and lock washers attaching the head to the pump body. Use two (2) jaw pullers, **Tool T05** simultaneously to pull off first head as shown in **Photo 116**. Remove the square-ring rubber gasket between the head and pump body section. **CAUTION:** When using the two jaw pullers (**Tool T05, Photo 116**) to remove the first head from the pump assembly, it is important to apply equal pressure to each of the pullers. Only tighten the puller handle by one (1) revolution at a time, alternating from puller to puller. The pump head must be pulled away from the pump body evenly to avoid damage to the shaft and rotor assemblies. **NOTE:** Do not reuse any seals or gaskets.
8. Place pump on bench as shown and use jaw puller **Tool T05** to push the shaft/rotor assemblies out of head. (**Photo 117**).
9. Remove the twelve (12) bolts and lock washers from the other pump head, and separate it from the pump body using 1/2"-13 x 1 1/2" full thread bolts in each of the two (2) tapped holes located on opposite corners of the pump head. Refer to **Photo 112** on **Page 14** for the tapped hole location and **Page 18** for details. **NOTE:** Remove the pump head by using equal turns on each of the two (2) bolts. Remove the square-ring gasket. **NOTE:** Do not reuse any seals or gaskets.
10. The four (4) roller bearings can now be removed from the pump heads. First loosen the socket head set screws that lock the bearing retainer nut as shown in **Photo 118**.
11. Now loosen and remove the four (4) bearing retainer nuts using a pin spanner wrench **Tool T01** as shown in **Photo 119**. If a suitable pin spanner is not available, it may be purchased from Trident as **Part # 29.007.0**.
12. The four (4) roller bearings can now be tapped out from their bore from the back side of the head using a small brass or plastic rod and light hammer. See **Photo 120**. If the repair was to replace the roller bearings, stop the disassembly here and refer to the assembly instructions starting on **Page 16**. *Otherwise continue to next step.*
13. The stationary portion of the four (4) mechanical seals can now be removed from the pump heads. Again use a small brass or plastic rod and light hammer to gently tap the seal half out from the back side. See **Photo 121**. **NOTE:** Do not reuse the mechanical seals. Only replace with OEM parts.
14. The rotating portion of the four (4) mechanical seals can be removed from the shaft/rotor assemblies by prying on the spring until the rubber boot can be pulled off the shaft. See **Photo 122**. **NOTE:** Do not reuse the mechanical seals. Only replace with parts that are approved by Trident Emergency Products.

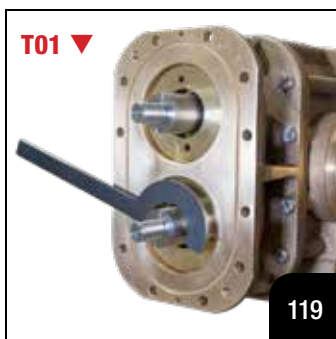
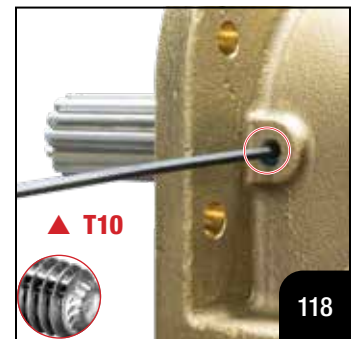
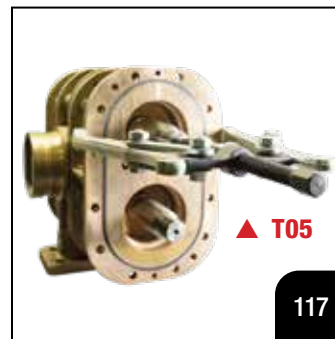
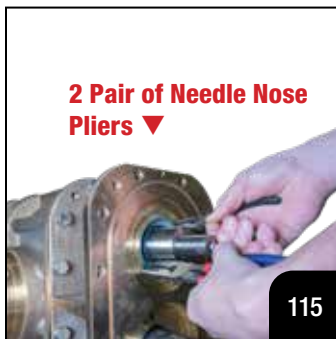

Pump Assembly - Rebuilding the Foam Pump

NOTE: Prior to installing bearings, it is recommended to hydrostatically test the pump at 500 PSI [34 Bar] for 5 minutes to ensure seal integrity.

- Place half of the mechanical seal into pump head. Apply a thin film of U.S. Sealube Rubber Lubricant Emulsion IFC Tool T25, or equivalent, to all rubber surfaces of the mechanical seal, then press into bore using the cardboard that was protecting the seal while it was in the box. **IMPORTANT:** Do not touch the sealing face of the seal. (See Photo #123 of seal in head).
- Install the other mechanical seal into the pump head as shown in Photo #124.
- Apply a thin film of U.S. Sealube Rubber Lubricant Emulsion IFC Tool T25, or equivalent, to all rubber surfaces of the mechanical seal and adjoining pump shaft, and then slide the seal onto the shaft and press into place using an appropriate seal pusher, use caution not to touch the sealing faces. See Photo #125 of mechanical seal on shaft, Tool T18 is used to press seal. **NOTE: All Sealing Faces of the Mechanical Seals Must Be Cleaned** using the supplied alcohol wipes.
- Place square seal rings into the pump body groove. Install roll pins as circled. (See Photo #126)
- Mate one pump head with the body being sure there are no contaminants on the sealing faces. Use 1/2" stainless steel bolts and lock washers, hand tighten only. Note the position of the "S" in the pump head casting, which marks the suction side of the pump. (See Photo #127 of one head installed onto pump body). **NOTE:** Verify that the Match Marks applied during disassembly (A-A) (B-B) align.
- Place the body and head assembly on bench with the head side down. (See Photo #128).
- Place the shaft/rotor assemblies into the body being careful not to damage the mechanical seals. Be sure the pump head face and rotor faces are clean of debris. (See Photo #128 of shaft assemblies in body/head assembly).
- Slide head onto pump assembly again being careful not to damage the seals. Be sure that the "S" marking the suction side of the pump is the same on both sides. Be sure that the face of the head is clean. Attach with bolts and lock washers. (See Photo #129 of other head going on). Torque the pump head bolts to a value of 54-55 lb-ft.
- Next install bearings. Position pump in arbor press as shown in Photo #130. Place the bearing onto the shaft and press bearing into place with bearing insertion tool, Tool T20. The opposite end of the shaft must be supported axially using Tool T05 to avoid damaging the heads and rotors. The bearing must be pressed completely onto the shaft, up against the shoulder on the shaft. Repeat this process for the remaining bearings making sure to support the opposite end of the shaft. After the bearings are installed, check that the pump shafts rotate freely. (Refer to Photo #130 and Page 18 for Bearing Press and Shaft Support Details). **NOTE: For proper bearing installation, Trident recommends the use of a bearing heater to assist in the expansion of the inner bearing race. To prevent possible bearing seal damage, do not exceed a temperature value of 250° F [120° C].**

⚠ WARNING

Only use parts approved by Trident Emergency Products when making pump repairs. Failure to do so will void pump warranty. When replacing mechanical seals follow seal manufacturer's installation instructions supplied with the new seals. **Never Reuse Old Seals.** Handle new seals carefully.

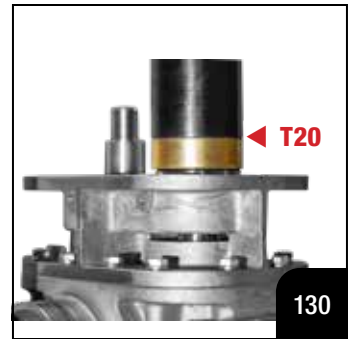
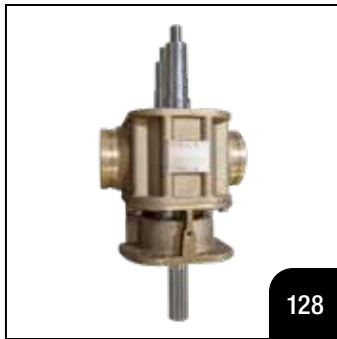
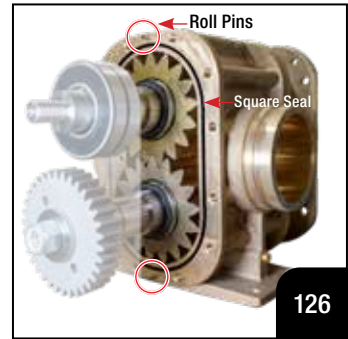

Pump Assembly (Continued)

Adjusting Rotor Clearance

1. Install bearing nuts loosely into heads. Place dial indicator **Tool T14** on one end of shaft. Apply a small amount of anti-seize compound **Tool T22** in two (2) spots of each bearing nut before screwing into the head.
2. Tighten bearing nut on one side all the way and zero the indicator. Then loosen the nut.
3. Tighten other adjusting nut and note total rotor clearance. Clearance should be 0.005" – 0.007" [.127 – .178mm]. Loosen adjusting nut.
4. Retighten adjusting nut from **Step 2** until indicator reads half of the total clearance. (See **Photo #131** showing dial indicator on shaft).
5. Slowly tighten opposing nut from **Step 3** until indicator begins to move. Do not overtighten. Using a #7 .201" [5.1mm] size drill bit, spot face the bearing nuts for the set screws. **NOTE:** Use caution as to not damage the threads for the set screws. Place the drill bit into the set screw hole and spot face the bearing nut to remove the threads allowing the set screw to seat properly. (See **Photo #132** of drill bit in set screw hole). **NOTE:** Vacuum out all metal filings remaining from the spotting operation.
6. Install set screws using blue thread locker **Tool T21** and tighten enough to secure bearing adjusting nuts. Do not overtighten. (See **Photo #133**).
7. Repeat process for the other shaft.

Oil Seal and Timing Gear Installation

1. Lay the brass oil seal holder on a bench with the groove side facing up. Use a hammer with a piece of wood to press the oil seal into the center of the holder. Be sure to position the seal in the same manner as shown in **Photo #134**. Install O-Ring, P/N 26.248.00 into the groove recessed into the outside diameter of the brass oil seal holder, lubricate the O-Ring with Parker Super O-Lube or equivalent after installation. Press the seal holder and seal into the pump head using your thumbs. Use caution not to damage the O-Ring while installing. Finally, using snap ring pliers (See **Photos #134 through #136**) reinstall the snap ring for each of the seal holders.
2. The order of timing gear installation is based on rotation of the input or drive shaft:
 - ▶ Pumps with Right-Hand (clockwise) driveshaft rotation: Install timing gear on lower shaft first.
 - ▶ Pumps with Left-Hand (counter-clockwise) driveshaft rotation: Install timing gear on upper shaft first.
 - ▶ Pump shaft rotation is viewed from the driveshaft end of the pump.
3. Place Drive timing gear onto the shaft. Use anti-seize compound **Tool T22** on threads and tighten locknut to 175 lb-ft. Use **Tool T17** to stop shafts from spinning while tightening. (See **Photo #137** with plastic block).
4. For reverse rotation, install Drive gear first then the Idler gear following the steps listed above.
5. Remove plastic block and be sure shafts spin freely. *Continued on next page.*

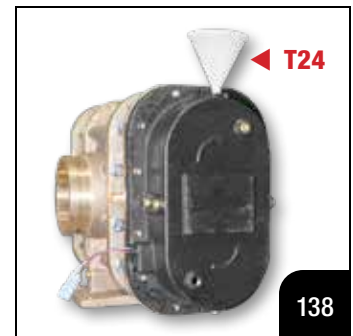
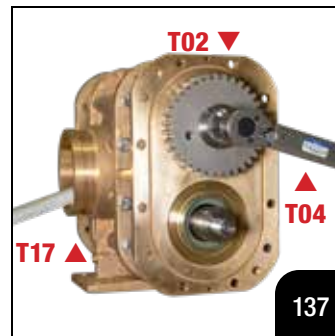
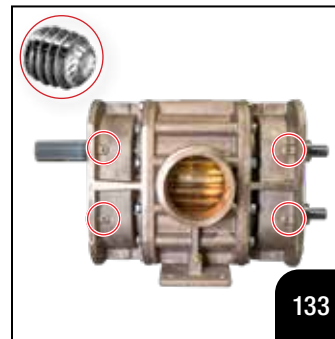
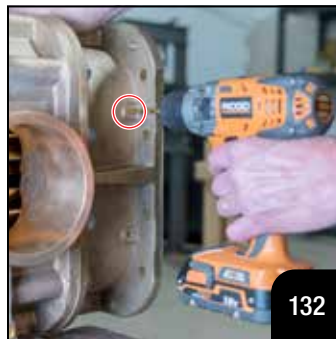
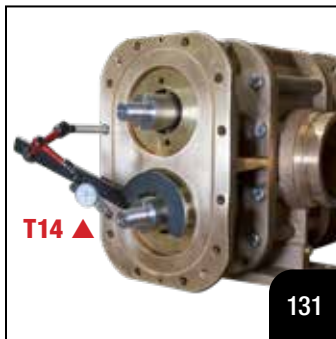

Pump Assembly (Continued)

Installing Timing Gears

6. Place round O-Ring into pump head and install timing gear cover using bolts and lock washers. Torque bolts to 54-55 lb-ft.
7. Fill oil to appropriate level according to pump mounting position. See images in **Figures 3 and 4 on Page 12** to select correct oil level check plug. Fill with a high quality SAE 30W (ISO Grade 100) conventional or synthetic oil. Failure to fill with appropriate amount of oil will damage the pump and void the warranty.
8. Reinstall breather vent into fill hole based on the orientation being used. See **Page 12** for proper placement of oil level check, oil fill, oil vent and oil drain.
9. Reinstall the hydraulic adapter/or bell housing/or cover plate and coupling previously removed with the original hardware.

Repair Kits and Special Tools

MINOR and **MAJOR** Repair Kits are available as follows:

MINOR: Timing Gears

Kit #27.020.16 Timing Gear Replacement Kit consisting of:

- 34-Tooth Timing Gear, 2-pieces · 15.007.0
- Timing Gear Locknut, 2-pieces · 04.074.0
- Timing Gear Cover O-Ring, 1-piece · 26.275.0
- Timing Gear Spacer, 2-Pieces · 24.018.0
- Split Lock Washer, 1/2" SS 12-Pieces · 04.125.0

MINOR: Bearings and Seals

Kit #27.020.12 Bearing and Seal Replacement Kit consisting of:

- Mechanical Seals, 4-pieces · 03.035.0
- Oil Seals – 2-pieces · 03.036.0
- 2 Row Sealed Spherical Bearings, 4-pieces · 16.012.0
- Pump Head to Body Square Seals, 2-pieces · 26.275.1
- Timing Gear Cover O-Ring, 1-piece · 26.275.0
- O-Ring Seal Holder, 2-pieces · 26.248.0
- Brass Bearing Adjusting Nut, 4-pieces · 04.073.2

TOOLS: Trident Tools for Bearing and Seal Replacement:

- Bearing Retainer Spanner Wrench (T01) · 29.007.0
- Gear Puller, Bolt on Style (T06) · 29.002.2
- Driver, Mechanical Seal (T18) · 29.003.2
- Roller Bearing Driver Tool (T20) · 29.005.2

MAJOR KIT for GP500: Minor Kits, Plus Major Components

Kit #27.020.10 Major Component Replacement Kit consisting of:

- Bearing and Seal Replacement Kit · 27.020.12
- Drive Shaft Assembly with Shaft, Rotor and Key · 05.056.0
- Driven Shaft Assembly with Shaft, Rotor and Key · 05.056.1
- Timing Gear Replacement Kit · 27.020.16

HARDWARE KIT for GP500

NOTE: This kit is required when ordering a MAJOR repair kit

Kit # 27.020.14 Fasteners for Pump Reassembly consisting of:

- Knurled cup SS set screw 1/4"-20 - 4-pieces · 04.114.0
- Hex nuts 1/2"-13, 12-pieces · 04.122.1
- Alignment roll pins, SS, 6-pieces · 17.010.0
- Timing gear locknut, 2-pieces · 04.074.0
- Split Lockwasher 1/2", SS, 48-pieces · 04.125.0
- Hex head cap screw 1/2"-13 x 1 1/2", SS, 48-pieces · 04.124.0
- Timing Gear Spacer, 2-pieces · 24.018.0

NOTE: Refer to **Page 24** for required repair tools.

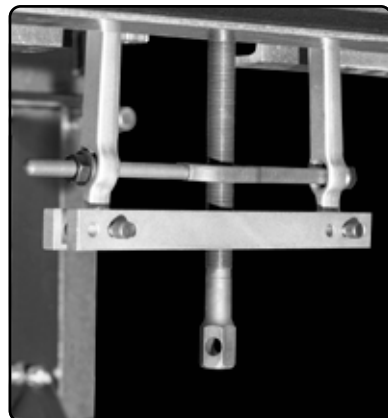

**Pump Head
1/2" - 13TPI
Tapped Holes
for Head Removal ►**

**◀ Example of
Bearing Press**



Troubleshooting Guide

Problem	Likely Cause	Corrective Action
Pump Does Not Turn	Pump Siezed.	Inspect pump rotors for foreign bodies, bearing failure, shaft damage – repair or replace as required.
	Faulty or Misaligned Coupling.	Inspect and replace or realign coupling as required.
	Pump Driver Inoperative.	Inspect and repair as required.
	Damaged/Missing Shaft/Rotor Key.	Replace shaft/rotor key.
Excessive Noise	Faulty or Misaligned Drive Coupling.	Inspect and repair/replace as required.
	Pump Cavitation.	Inspect pump suction piping for blockage and proper valve operation. Check piping with vacuum gauge – reading should be less than 10" hg.
	Worn or Damaged Bearings.	Repair or Replace Pump.
	Timing Gear Noise.	Timing gear noise can increase significantly over 900 RPM. Hearing protection is required.
	Pump Driver is Malfunctioning.	Inspect and repair as required.
Excessive Vibration	Faulty or Misaligned Drive Coupling.	Inspect and repair/replace as required.
	Pump Cavitation.	Inspect pump suction piping for blockage and proper valve operation. Check piping with vacuum gauge – reading should be less than 10" hg.
	Worn or Damaged Bearings.	Repair or Replace Pump.
Reduced or No Flow	Clogged Suction Strainer.	Clean or replace strainer screen.
	Pump Cavitation.	Inspect pump suction piping for blockage and proper valve operation. Check piping with vacuum gauge – reading should be less than 10" hg.
	Pump Body and/or Rotors Worn.	Inspect, repair or replace, as required.
	Low/Insufficient Pump Speed.	Inspect pump driver for proper speed range(s).
	Incorrect Pump Shaft Rotation.	Verify pump is running in correct rotation, and pump rotation was ordered and shipped correctly.
Lubrication	Oil Temperature.	Excessive oil temperatures will breakdown the lubrication properties and lead to excessive timing gear wear. Temperature should be monitored.
	Oil Level.	Oil level and quality must be maintained as outlined under the Periodic Pump Inspection and Maintenance.
	Oil Type.	Use a high quality SAE 30W [ISO Grade 100] oil when adding or changing lubricant. Conventional or Synthetic oils are acceptable.
	Oil Change Interval.	Oil must be changed as outlined under the Periodic Pump Inspection and Maintenance.

Relief Valve Information



Trident Emergency Products can provide a relief valve suitable for any model and size of foam pump. Relief valves are constructed of all bronze/brass and stainless steel with EPDM seating and are suitable for any type of foam concentrate. Valves are available with set pressures from 50 PSI to 330 PSI.

Contact Trident for a Relief Valve Data Sheet to assist in selecting the proper valve size based on required pump flow and operating pressure.

Periodic Pump Inspection and Maintenance

WARNING

Pump inspection, maintenance and/or removal require close proximity to pump driver or drivelines. Observe proper **Lock-Out/Tag-Out Procedures** to prevent accidental start-up and potential bodily injury or equipment damage.

Failure to perform routine pump maintenance and installation inspection can lead to pump or system failure.

Pump and Installation Inspection

1. Check timing gear oil level by removing appropriate level check plug (based on pump mounting orientation) as shown on **Page 12**. Add high quality SAE 30W [ISO Grade 100] conventional or synthetic oil as required. This check should be done monthly.
2. Inspect pump for leaks at seals, pump heads to pump body and timing gear cover to pump head and repair as required. Contact Trident Emergency Products for correct pump repair parts.
3. During pump inspection, or after any repairs, perform the following checks:
 - a. Inspect drive coupling and drive components for misalignment, loose fasteners, signs of excess wear or damage and repair/replace as required.
 - b. Inspect pump mounting fasteners for proper torque, signs of excess wear or damage and repair/replace as required. Do not reuse previously torqued bolts.
 - c. Inspect all piping connections. Check Victaulic connections for leaks, loose, worn or damaged coupling sections and fasteners, and repair/replace as required. Piping system must be air tight.
 - d. Inspect system valves for proper operating condition and stand-by positions.
 - e. Inspect, clean and flush suction side strainer located between the foam tank and foam pump (not supplied) of foreign matter.
 - f. Operate the system at enough pressure to open the relief valve and verify flow and system pressure drop. Once re-seated, the relief valve should not leak.

Pump Maintenance

1. Oil should be drained and replaced every six (6) months with high quality SAE 30W [ISO Grade 100] conventional or synthetic oil.
2. See **Page 18** of this manual for Minor and Major repair kits. When ordering pump parts, always provide pump model and serial number. Only use parts approved by Trident Emergency Products when performing repairs to the pump.

Pump Removal for Repair

CAUTION

Rotary gear pumps are heavy and service personnel should use equipment with the proper weight rating for lifting pumps, and utilize correct personal protection equipment when performing repairs and handling heavy loads.

1. Disconnect pump drive device and observe established **Lock-Out/Tag-Out Procedures**.
2. Close the tank supply and return valves.
3. Drain suction and discharge piping. Drain pump.
4. Disconnect suction and discharge piping connections allowing room for pump removal.
5. Properly support and secure pump prior to loosening mounting hardware.
6. Remove pump from installation and perform repairs in a clean environment. Follow disassembly and assembly instructions listed in this manual.
7. Drain oil prior to pump disassembly and dispose of properly.
8. See **Page 28** of this manual for repair/replacement parts. When ordering pump parts always provide the pump model and serial number. **NOTE:** Only use parts approved by Trident Emergency Products when performing repairs to the pump.
9. Minor and Major repair kits are listed on **Page 18**.
10. Repair tools are listed on **Page 24**.

Required Repair Tools

The following standard and specialized tools are required when performing pump repair and maintenance:

ITEM	DESCRIPTION	QUANTITY	TRIDENT PART NUMBER
T01	Bearing Retainer Spanner Wrench	1	29.007.0
T02	Socket for Timing Gear Nuts 1 7/16" x 1/2" Drive	1	
T03	Breaker Bar 1/2" Drive	1	
T04	Torque Wrench, 1/2" Drive, Foot Pound Calibration	1	
T05	Puller, Claw Style, 8" Adjustable Dual Jaw	2	
T06	Gear Puller, Bolt On Style	1	29.002.2
T07	Ratchet Wrench 3/8" Drive	1	
T08	Socket 5/16" x 3/8" Drive	1	
T09	Combination Wrench 3/4"	1	
T10	Allen Wrench for Bearing Retainer Nut Set Screws 1/8"	1	
T11	Allen Wrench for Magnetic Drain Plug 1/4"	1	
T12	Wrench for Oil Fill/Breather 7/16"	1	
T13	Oil Seal Snap Ring Pliers	1	
T14	Dial Indicator, Must Have .015 Minimum Travel in .0005 Increments	1	
T15	Not Used On This Model.	0	
T16	Hammer, Dead Blow	1	
T17	Poly Block, 3/4" Thick x 4" Wide x 10" Long	1	
T18	Driver, Mechanical Seal, PVC Conduit	1	29.003.2
T19	O-Ring Lubricant, Parker Super O-Lube	1	
T20	Driver, Bearing Insertion Tool	1	29.005.2
T21	Thread Locker, Blue, Loctite 243	1	
T22	Anti Seize Compound, Copper Grade	1	
T23	Oil, SAE 30W [ISO Grade 100], Conventional or Synthetic	See Notes on Page 12	
T24	Funnel, Oil Fill, Maximum Bottom Outside Diameter .375"	1	
T25	Lubricant for Mechanical Seals, US Sealube Rubber Lubricant Emulsion IFC or equivalent	1	



Warranty and Product Information

Warranty

Trident Emergency Products (Seller) warrants its GP Series™ rotary gear foam pumps to be free of defects in materials and workmanship under normal use and service for which the products were designed to the Buyer. This warranty is for a period of 60-months after shipment from factory. Seller must be notified in writing within the warranty period of any defects and shall have the option of requiring the return of parts or entire pump to its factory for verification of any claim. Seller will have the sole discretion in determining whether a pump is defective, and to make determination to repair or replace said pump during the warranty period. Attempt by Buyer or End User to make alterations or repairs to a pump during the warranty period without written consent by Seller will void the warranty.

The use of non-Trident specific parts to make repairs without written consent by the Seller will void the warranty.

THIS WARRANTY IS THE SOLE WARRANTY OF SELLER AND SELLER HEREBY EXPRESSLY DISCLAIMS AND BUYER WAIVES ALL OTHER WARRANTIES EXPRESSED, IMPLIED IN LAW OR IMPLIED IN FACT, INCLUDING ANY WARRANTIES OF MERCHANTABILITY OR FITNESS FOR A PARTICULAR PURPOSE.

Seller's sole obligation under this warranty shall be, at its option, to repair or replace any equipment (or its component parts) which has a defect covered by this warranty, or to refund the purchase price of such equipment or part. Under the terms of this warranty, Seller shall not be liable for (a) consequential, collateral, special or liquidated losses or damages; (b) equipment conditions caused by normal wear and tear, abnormal conditions of use, accident, neglect, or misuse of said equipment; (c) the expense of, and loss or damage caused by, repairs or alterations made by anyone other than the Seller; (d) damage caused by abrasive materials, chemicals, scale deposits, corrosion, mishandling, or other similar conditions; (e) any loss, damage, or expense relating to or resulting from installation, removal or reinstallation of equipment; (f) any labor costs or charges incurred in repairing or replacing defective equipment or parts, including the cost of reinstalling parts that are repaired or replaced by Seller; (g) any expense of shipment of equipment or repaired or replacement parts; or (h) any other loss, damage or expense of any nature.

The warranty shall not apply to any additional Trident supplied equipment, or Buyer/End User supplied equipment, associated with pump operation that is covered by another manufacturer's separate or special warranty, such as motors, engines, couplings, relief valves, pump control panels, etc. Pump defects caused by improper installation and plumbing connections, failure to follow installer responsibilities and periodic pump inspection and maintenance outlined in the O&M Manual, and operating the pump outside of the intended parameters established by the Seller will void the warranty. The failure to provide proper discharge over-pressure protection in the form of a relief valve or other device or system will void the warranty.

PERFORMANCE: Equipment performance outlined on submitted curves is based on water as a medium. Performance may vary based on actual medium pumped and power applied.

LIABILITY LIMITATIONS: Under no circumstances shall the Seller have any liability under the Order or otherwise for liquidated damages or for collateral, consequential or special damages or for loss of profits, or for actual losses or for loss of production or progress of construction, regardless of the cause of such damages or losses. In any event, Seller's aggregate total liability under the Order or otherwise shall not exceed the contract price.

MODELS COVERED: This warranty covers the following models: GP30, GP60, GP120, GP160, GP200, GP300, GP350 and GP500.

DOCUMENT #99.013.6 • EFFECTIVE DATE May 22, 2019



Ordering

Please use Trident part numbers and descriptions when placing orders. All orders must be type written and sent along with your quote via E-Mail to (sales@tridentdirect.com). All orders will be acknowledged by Trident within 2 business days and shall become final after acknowledgment, if not challenged. *No verbal orders will be accepted.*



Freight

All orders are shipped EX-Works Hatboro, PA, USA. Our responsibility ceases upon delivery to common carrier. Consignee must file claim for storage and damaged freight with the carrier.

Return Policy

No material will be accepted for return without authorization by the factory, and a return goods authorization number assigned. Materials must be returned prepaid. A 20% restocking fee normally applies. No material accepted for credit after one year from purchase date.



Customer Service Phone (215) 293-0700

We pride ourselves with exceptional customer service and are available to answer questions pertaining to new or existing orders and any of your after the sale support concerns. If a product needs to be returned, please call and request a Returned Goods Authorization (RGA) number. Warranty claims must be made by an authorized TRIDENT employee. Be prepared to provide the product model number and purchase invoice number. Replacement parts ordered will be invoiced to your account. Once an RGA number is received you must write it on all boxes and paperwork. TRIDENT will not accept your returned goods without an RGA number. Upon receiving the return, if it is determined to be covered under warranty, a credit memo will be issued and mailed to you for your records.



Note: All designs, specifications, and dimensional data contained in this catalog are subject to change without notice. No additional warranties, express or implied, including warranties of merchantability for fitness for a particular purpose, are created by the descriptions and depictions of the products on or in this catalog. Not responsible for typographical errors.

Repair/Replacement Parts

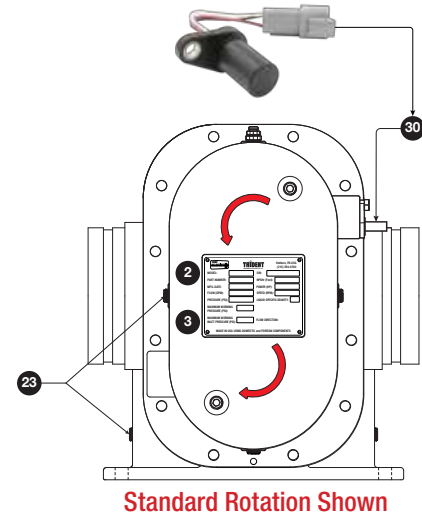
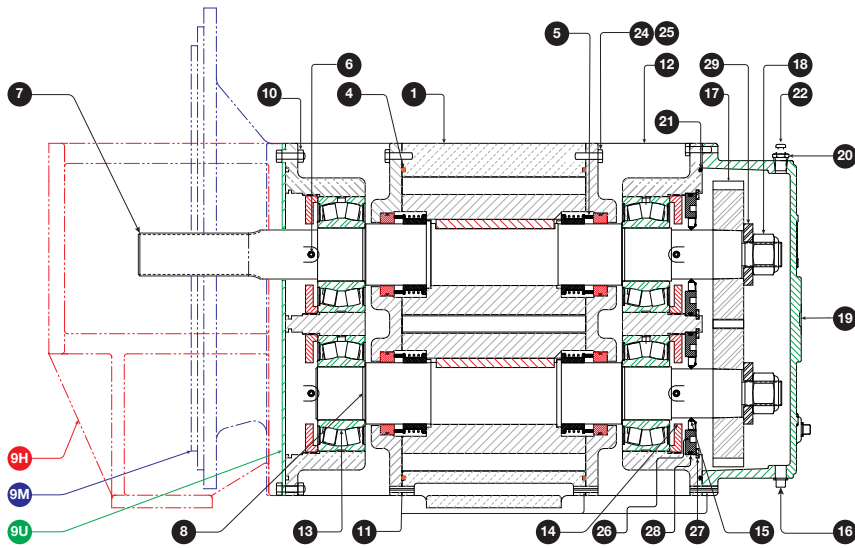

REF #	DESCRIPTION	QTY	PART #	MATERIAL
1	Pump Body GP500	1	07.048.0	C83600 Brass
2	Nameplate, Pump Data	1	02.026.4	C26000 Brass
3	Drive Pins, #4, Nameplate Attachment, Stainless Steel	4	04.115.0	18-8 Stainless Steel
4	Sealing Ring, Square, Pump Head to Pump Body	2	26.275.1	EDPM, 70 Durometer
5	Mechanical Seals	4	03.035.0	Silicon Carbide Seat, Carbon Face, SS Hardware, EPDM Boot & O Ring
6	1/4"-20 Knurled Cup Point Stainless Steel Set Screw	4	04.114.0	18-8 Stainless Steel
7	Drive Shaft Assembly with Rotor and Key for GP500	1	05.056.0	Shaft: 17-4 PH Stainless Steel, Rotor: C95400 Alum Bronze, Key: AISI 304 SS
8	Driven Shaft Assembly with Rotor and Key for GP500	1	05.056.1	Shaft: 17-4 PH Stainless Steel, Rotor: C95400 Alum Bronze, Key: AISI 304 SS
9H	Hydraulic Motor Adapter - SAE D - 2/4 Bolt Mount for GP500	1	18.025.0	SAE G3500 Gray Iron
9M	Gas/Diesel Engine Bell Housing Adapter SAE 2/3 for GP500	1	07.037.1	SAE G3500 Gray Iron
9U	Universal End Plate	1	18.026.0	AISI 304 Stainless Steel
10	1/2"-13 Stainless Steel Nuts for End Plate Mounting	12	04.122.1	18-8 Stainless Steel
11	Alignment Roll Pins	6	17.010.0	18-8 Stainless Steel
12	Pump Head	2	06.004.0	C83600 Brass
13	Double Row Spherical Roller Bearing, Sealed	4	16.012.0	Steel
14	Adjusting Nut	4	04.073.2	Alloy 360 Brass

REF #	DESCRIPTION	QTY	PART #	MATERIAL
15	Oil Seals	2	03.036.0	Steel Housing, Buna-N Seal
16	1/4" NPT Pipe Plug, Oil Drain, Magnetic Tip	1	09.005.3	Plated Steel
17	Timing Gears, 34 Tooth	2	15.007.0	SAE E4140 or 4340 Steel Heat Treated
18	Lock Nuts, Timing Gear	2	04.074.0	Zinc Plated Grade 2 Steel
19	Timing Gear Cover	1	08.042.0	SAE G3500 Gray Iron
20	Bushing, Brass, 1/4" NPT M x 1/4" NPT F	1	09.006.0	Brass
21	O-Ring, Round, Timing Gear Cover to Head	1	26.275.0	Nitrile 70 Durometer
22	Oil Fill and Vent, 1/4" NPT	1	09.061.0	Plated Steel
23	1/4" NPT M Pipe Plug, Brass, Socket Head	6	09.005.2	Brass
24	1/2" Split Lock Washer, Stainless Steel	36	04.125.0	18-8 Stainless Steel
25	1/2"-13 Hex Head Stainless Steel Bolts	36	04.124.0	18-8 Stainless Steel, ASTM F593C
26	Seal Holder	2	24.016.1	Alloy 360 Brass
27	Retaining Ring, Internal	2	04.110.3	Black Finish Steel
28	O-Ring Seal	2	26.248.0	Buna-N
29	Spacer, Timing Gear Nut	2	24.018.0	AISI 1020 Steel
30	Optional Speed Sensor	1	49.001.1	Glass Filled Nylon

Example nameplate shown. If a replacement nameplate is needed, contact Trident with your pump serial number.

Trident Emergency Products, LLC

2940 Turnpike Drive | Suite #9 | Hatboro, PA 19040 USA
 215-293-0700 **Phone**
 215-293-0701 **Fax**
 sales@tridentdirect.com **Email**

TridentDirect.com

05/04/2020
 P/N: 99.013.5



<https://www.facebook.com/tridentemergency>



**World Class
 Fire Industry
 Products**

GP Series™ is a trademark of
 Trident Emergency Products, LLC