

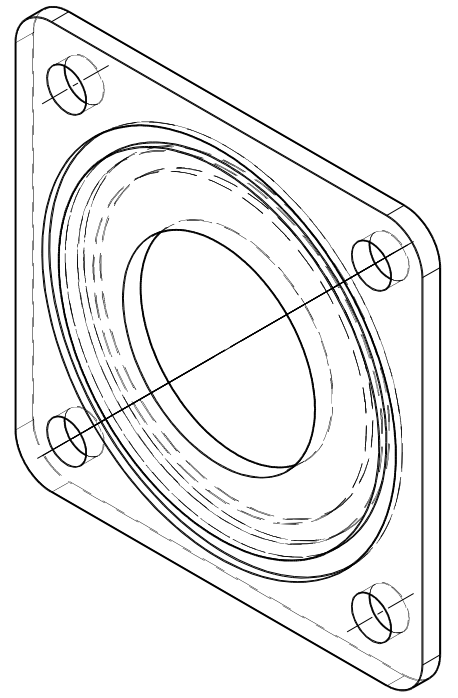

REVISIONS				
ZONE	REV	DESCRIPTION	DATE	APPROVED

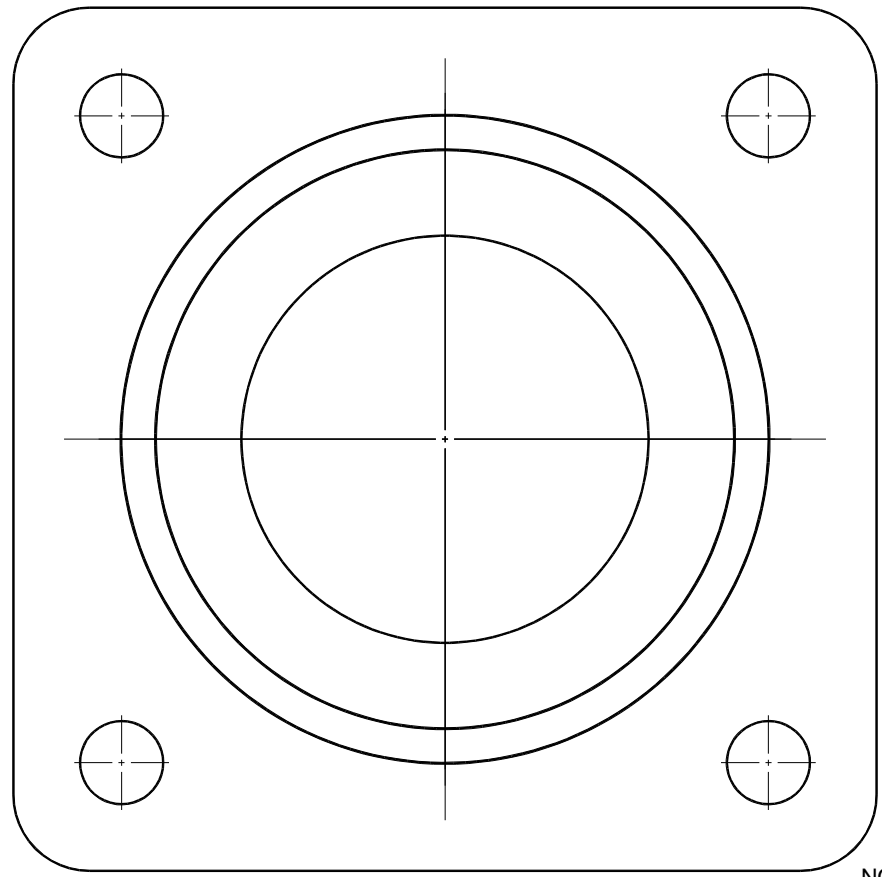
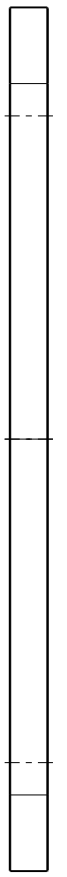
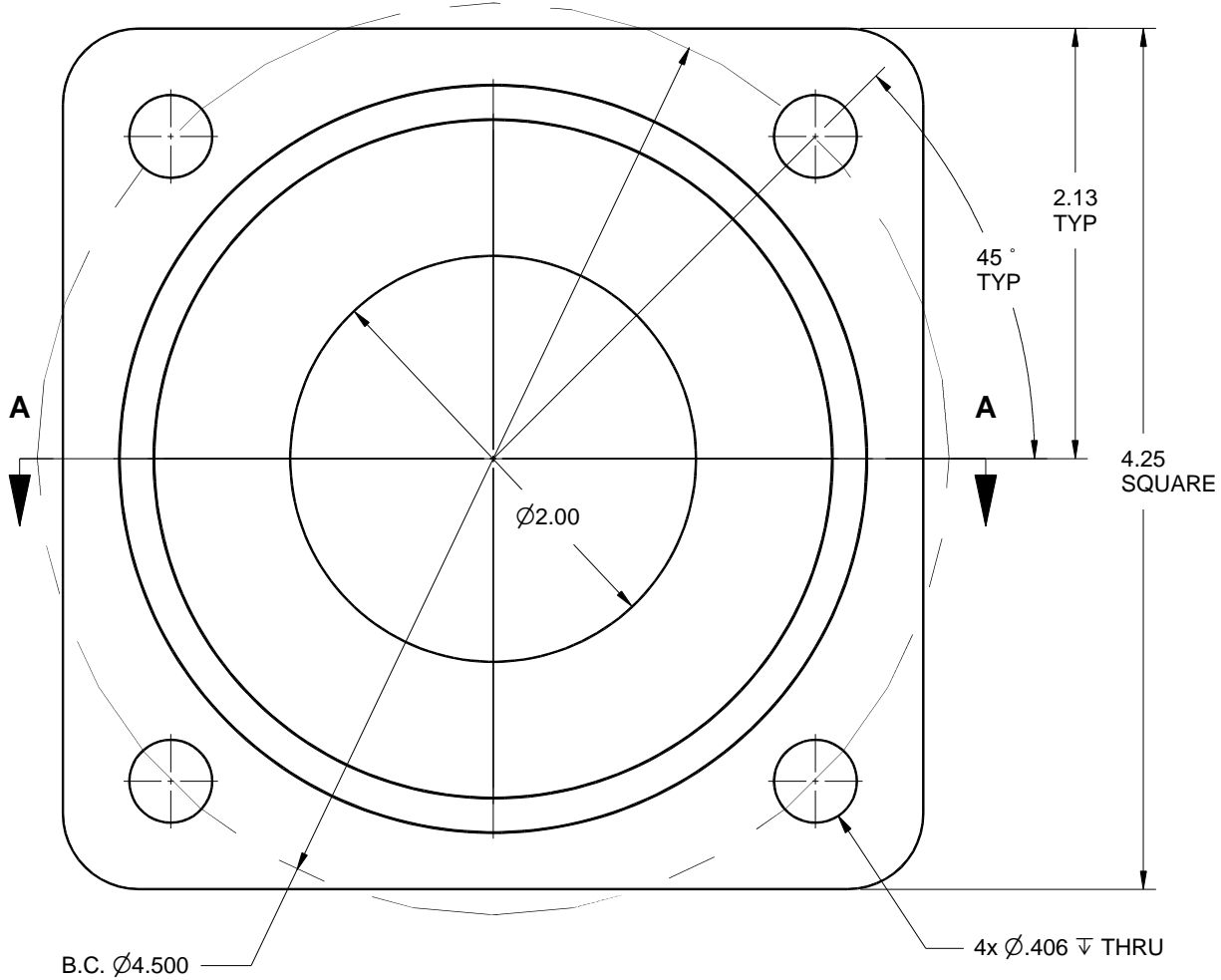

- NOTES:
1. MATERIAL - ALUMINUM
  2. HARD COAT ANODIZE

Volume = 1.5 in<sup>3</sup>  
Mass = .067 kg

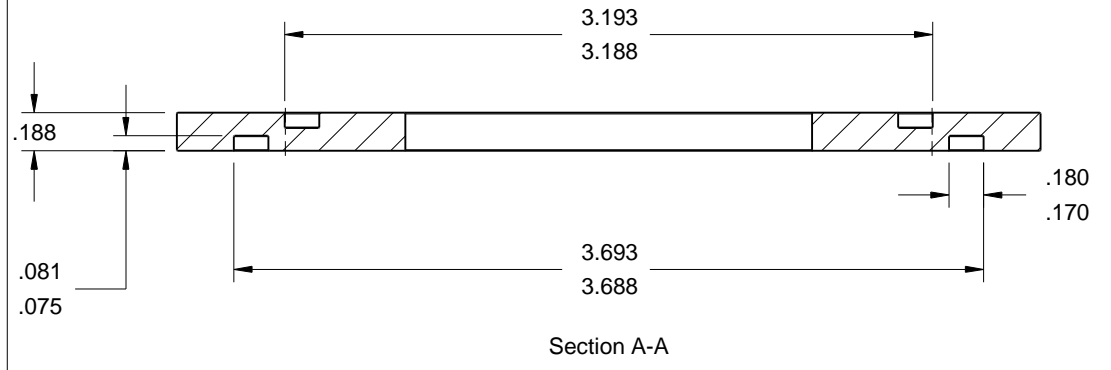

REMOVE ALL SHARP EDGES ALL DIMENSIONS ARE INCHES STANDARD TOLERANCES: .XX +/- .020 .XXX +/- .010 ANGLES +/- .5°	DRAWN MS	DATE 09/10/2013	<b>TRIDENT EMERGENCY PRODUCTS, LLC</b> <i>"Tomorrow's Ideas Delivered Today"</i>			
	CHECKED					
COPYRIGHT © DRAWING NOT TO BE REPRODUCED OR USED TO MAKE OTHER DRAWINGS OR MACHINERY	QA		<b>FLANGE, 2" MANIFOLD ADAPTER</b>			
	MFG					
APPROVED			SIZE <b>B</b>	FSCM NO. 	DWG NO. 08.037.1	REV 
			SCALE 1:1		SHEET 1 OF 1	

