

REVISIONS				
ZONE	REV	DESCRIPTION	DATE	APPROVED

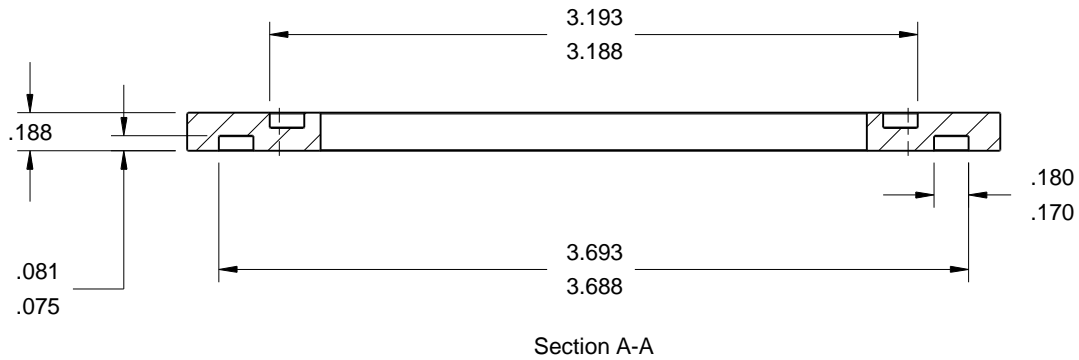
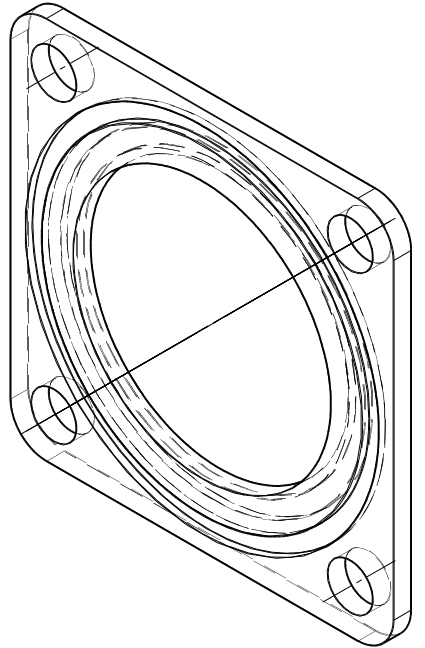
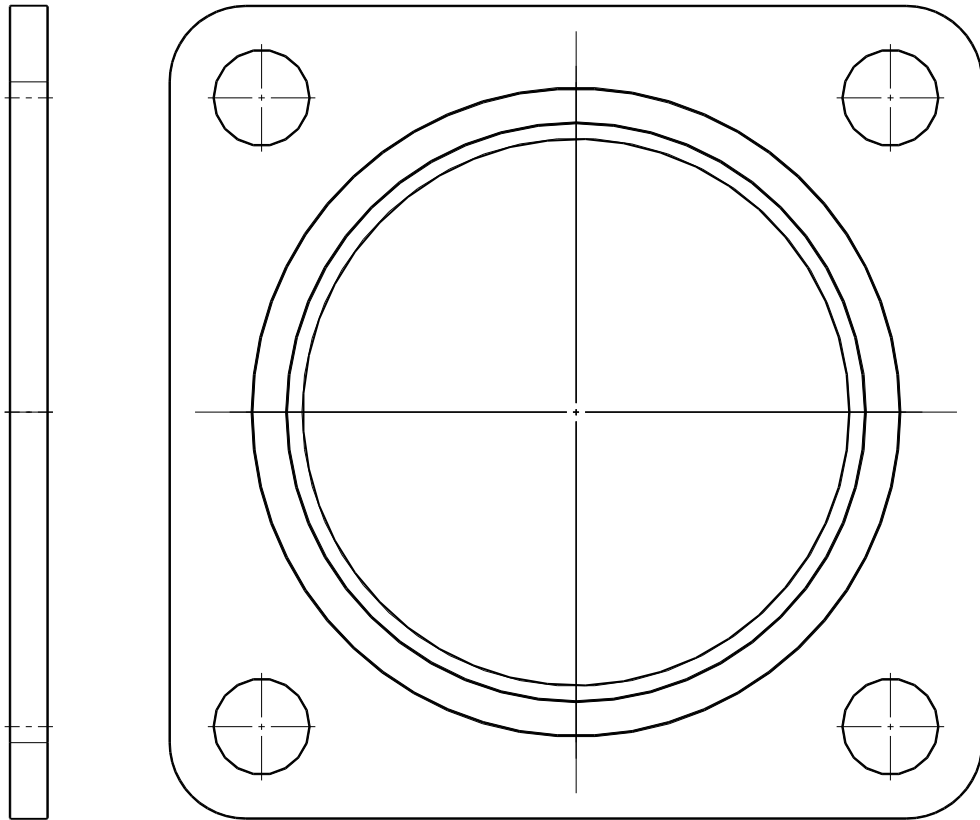
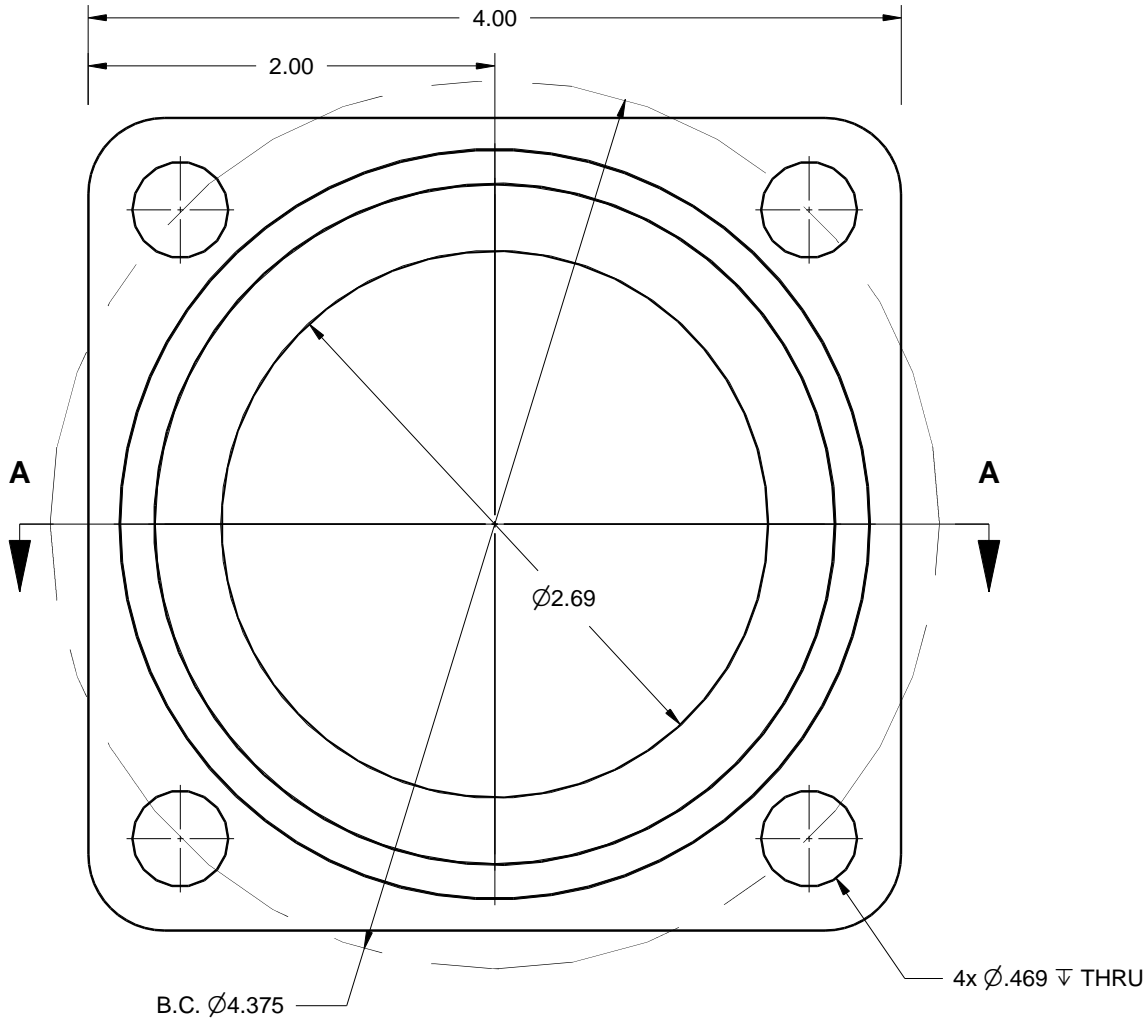
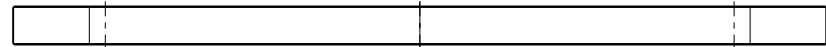

Volume = 1.5 in³
Mass = .067 kg

- NOTES:
1. MATERIAL - ALUMINUM
2. HARD COAT ANODIZE

REMOVE ALL SHARP EDGES ALL DIMENSIONS ARE INCHES STANDARD TOLERANCES: .XX +/- .020 .XXX +/- .010 ANGLES +/- .5°	DRAWN MS	DATE 09/09/2013	TRIDENT EMERGENCY PRODUCTS, LLC <i>"Tomorrow's Ideas Delivered Today"</i>			
	CHECKED					
COPYRIGHT © DRAWING NOT TO BE REPRODUCED OR USED TO MAKE OTHER DRAWINGS OR MACHINERY	QA		FLANGE, MANIFOLD ADAPTER			
	MFG					
	APPROVED		SIZE B	FSCM NO.	DWG NO. 08.037.0PC	REV
			SCALE 1:1		SHEET 1 OF 1	