

NOTES:

- 1. MATERIAL - ALUMINUM
- 2. HARD COAT ANODIZE

REVISIONS				
ZONE	REV	DESCRIPTION	DATE	APPROVED

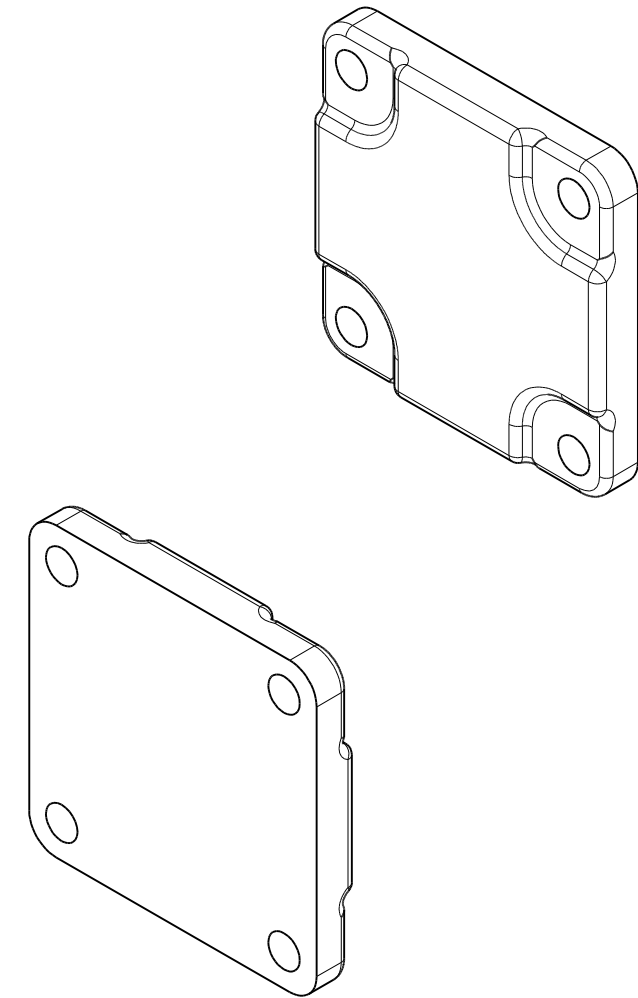
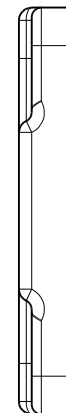
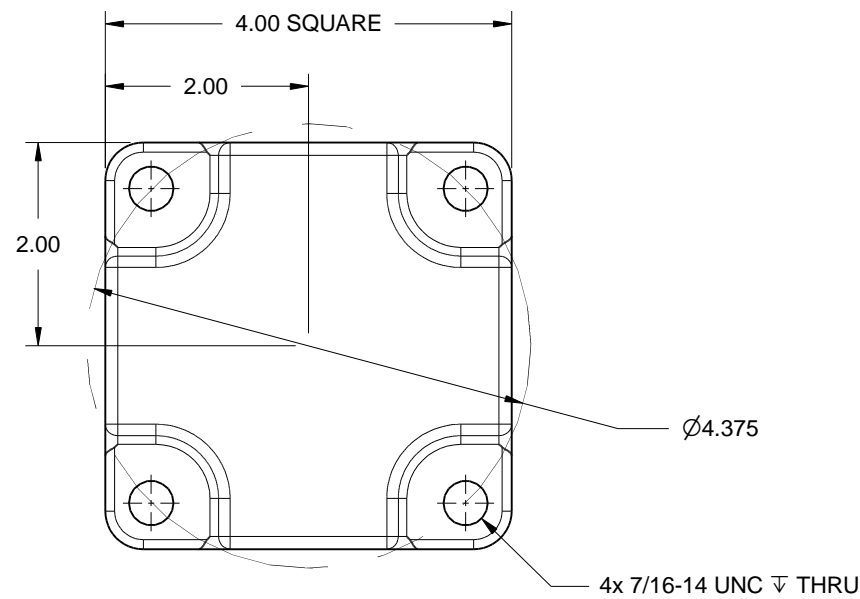
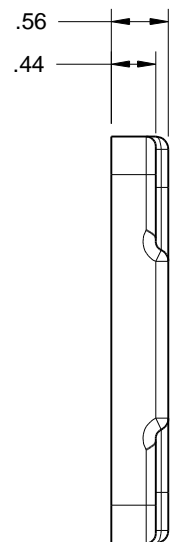

Volume = 8.1 in³
 Mass = 0.36 kg
 Surface Area = 40.2 in²

REMOVE ALL SHARP EDGES ALL DIMENSIONS ARE INCHES STANDARD TOLERANCES: .XX +/- .015 .XXX +/- .005 ANGLES +/- .5°	DRAWN	DATE	TRIDENT EMERGENCY PRODUCTS, LLC <i>"Tomorrow's Ideas Delivered Today"</i>			
	MS	09/10/2013				
	CHECKED		FLANGE, 2.5" MANIFOLD BLANK, ALUMINUM			
	QA					
COPYRIGHT © DRAWING NOT TO BE REPRODUCED	MFG		SIZE	FSCM NO.	DWG NO.	REV
OR USED TO MAKE OTHER DRAWINGS OR MACHINERY	APPROVED		B		08.036.0PC	
			SCALE	1:2	SHEET	1 OF 1