

NOTES:

- 1. MATERIAL - ALUMINUM
- 2. HARD COAT ANODIZE

| REVISIONS | | | | |
|-----------|-----|-------------|------|----------|
| ZONE | REV | DESCRIPTION | DATE | APPROVED |
| | | | | |
| | | | | |

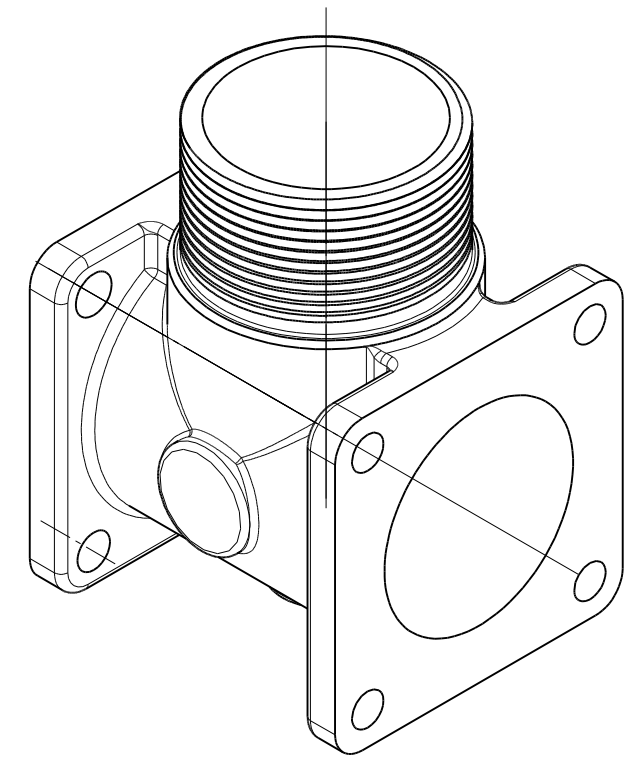
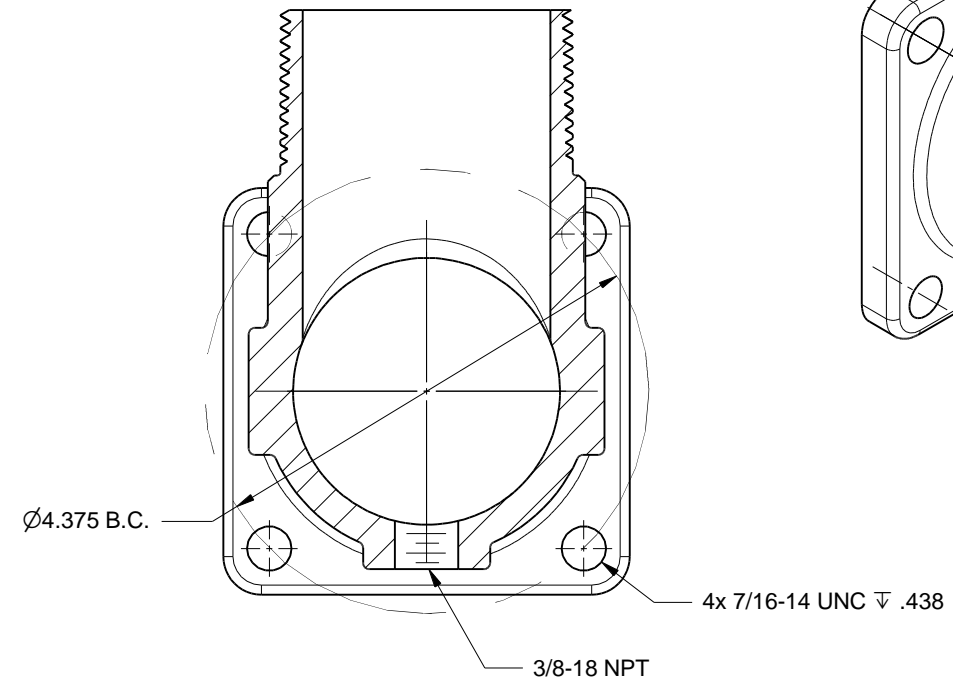
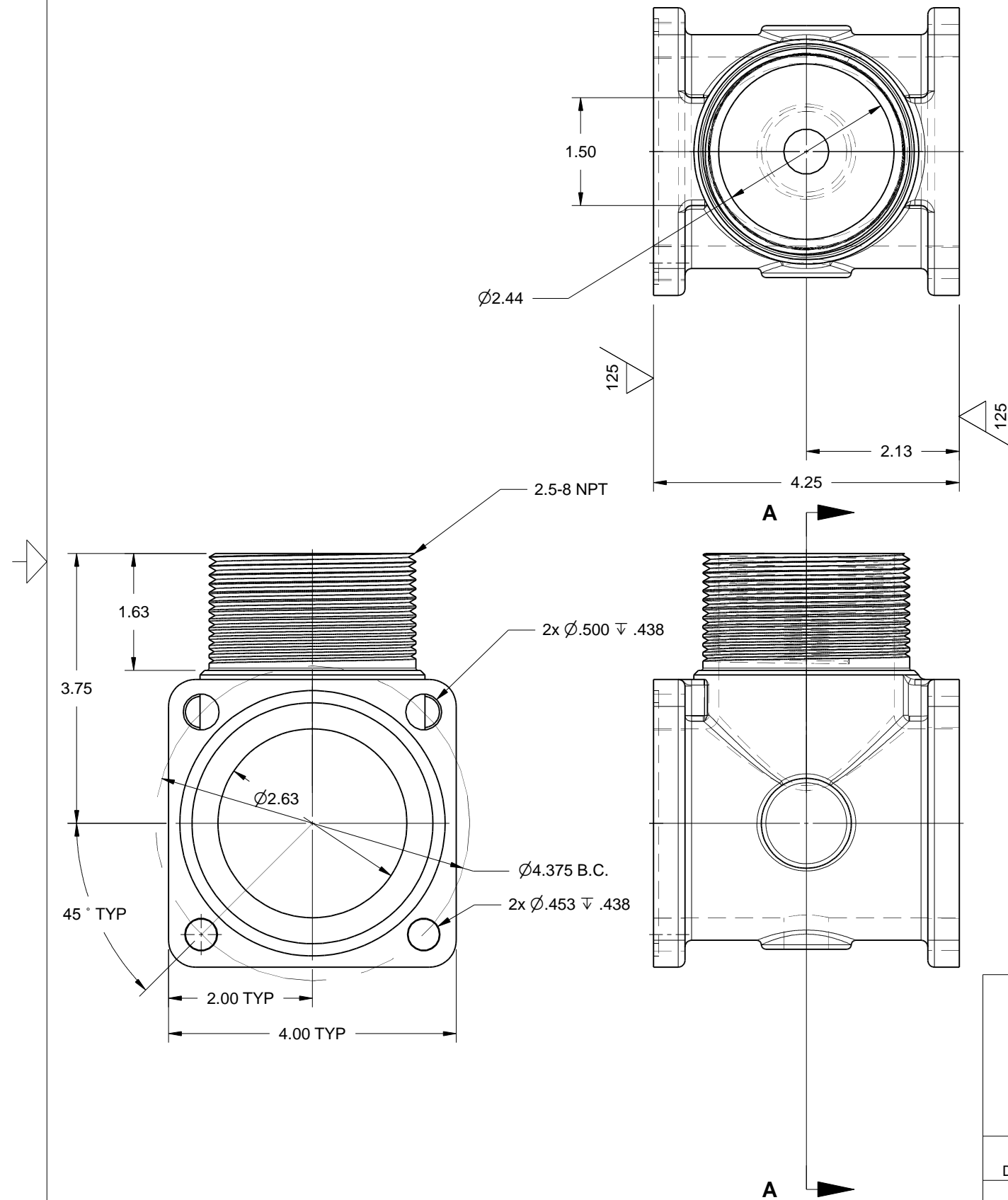

Volume = 22.3 in³
 Mass = 0.99kg
 Surface Area = 164 in²

| | | | | | |
|--|--|----------|------------|--|----------|
| REMOVE ALL SHARP EDGES ALL DIMENSIONS ARE INCHES STANDARD TOLERANCES: .XX +/- .015 .XXX +/- .005 ANGLES +/- .5° | | DRAWN | DATE | TRIDENT EMERGENCY PRODUCTS, LLC <i>"Tomorrow's Ideas Delivered Today"</i> BODY, DISCHARGE MANIFOLD 2.5" NPT ALUMINUM | |
| | | MS | 10/16/2013 | | |
| COPYRIGHT © DRAWING NOT TO BE REPRODUCED OR USED TO MAKE OTHER DRAWINGS OR MACHINERY | | CHECKED | | SIZE | FSCM NO. |
| | | QA | | B | |
| | | MFG | | DWG NO. | REV |
| | | APPROVED | | 07.030.25PC | |
| | | SCALE | 1:2 | SHEET | 1 OF 1 |