

NOTES:

- 1. MATERIAL - ALUMINUM
- 2. HARD COAT ANODIZE

REVISIONS				
ZONE	REV	DESCRIPTION	DATE	APPROVED

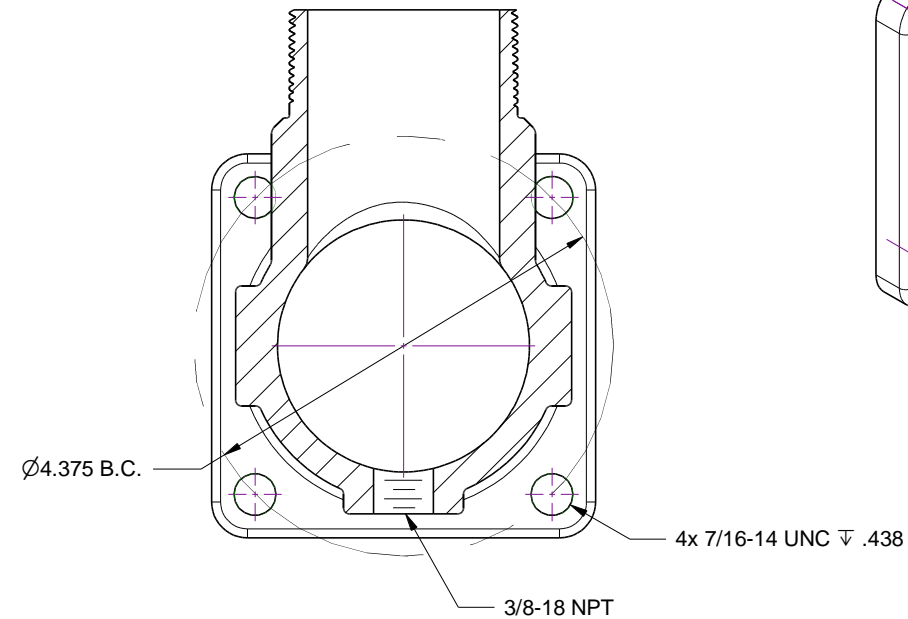
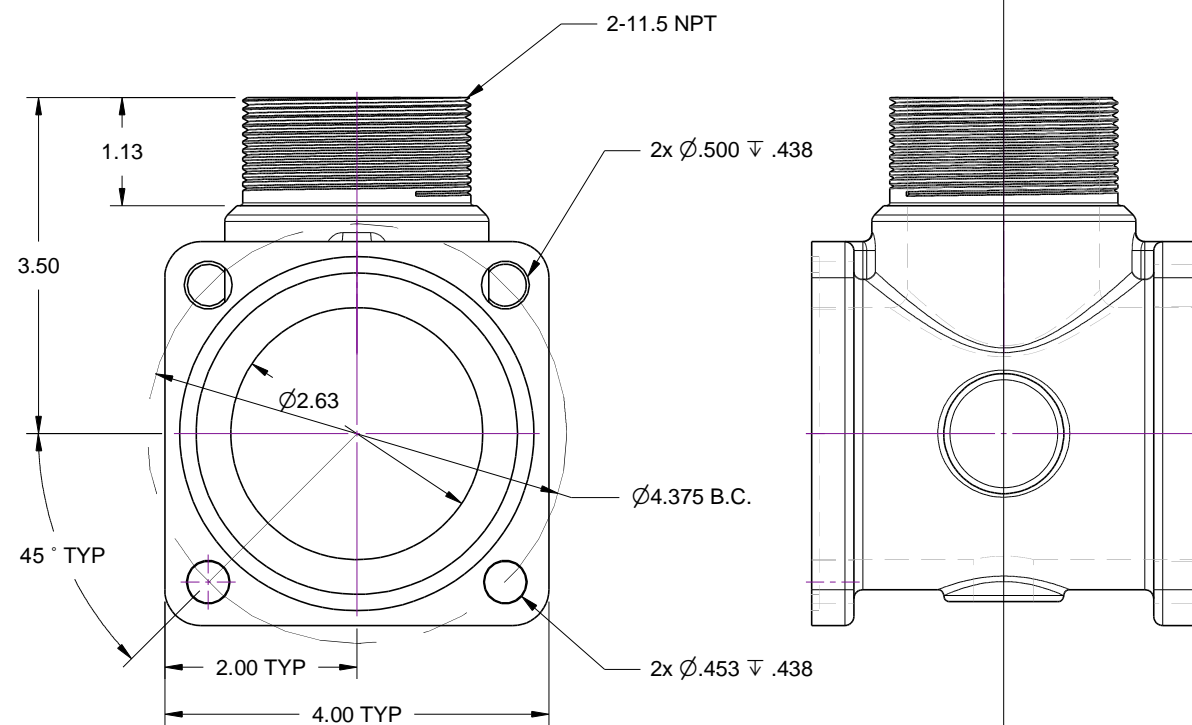
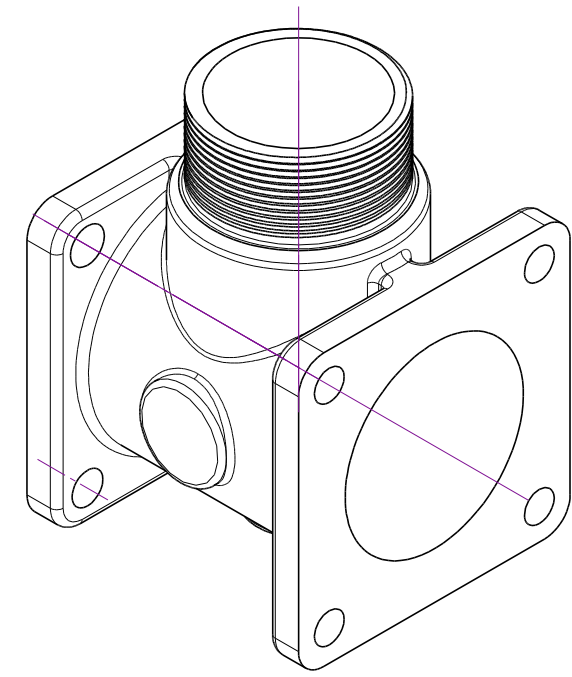
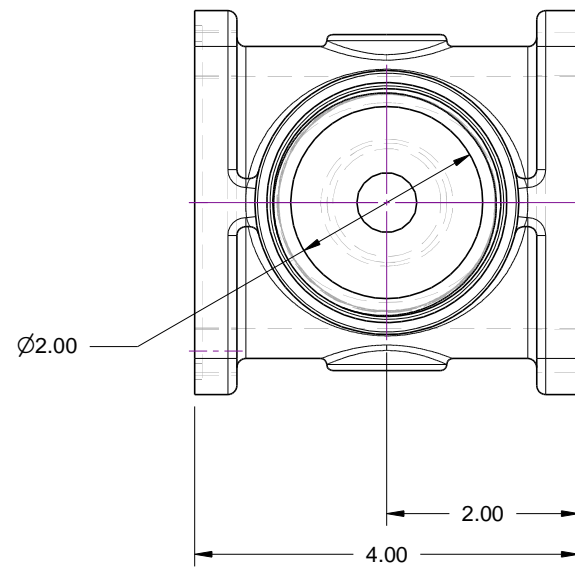

Volume = 20.9 in³
 Mass = 0.93 kg
 Surface Area = 147 in²

REMOVE ALL SHARP EDGES ALL DIMENSIONS ARE INCHES STANDARD TOLERANCES: .XX +/- .015 .XXX +/- .005 ANGLES +/- .5°	DRAWN MS	DATE 10/16/2013	TRIDENT EMERGENCY PRODUCTS, LLC <i>"Tomorrow's Ideas Delivered Today"</i>		
	CHECKED		BODY, DISCHARGE MANIFOLD 2" NPT ALUMINUM		
	QA		SIZE B	FSCM NO.	DWG NO. 07.030.20PC
	MFG		SCALE 1:2	SHEET	REV 1 OF 1
APPROVED					
COPYRIGHT © DRAWING NOT TO BE REPRODUCED OR USED TO MAKE OTHER DRAWINGS OR MACHINERY					