

NOTES:

- 1. MATERIAL - A356-T6 ALUMINUM
- 2. HARD COAT ANODIZE

REVISIONS				
ZONE	REV	DESCRIPTION	DATE	APPROVED

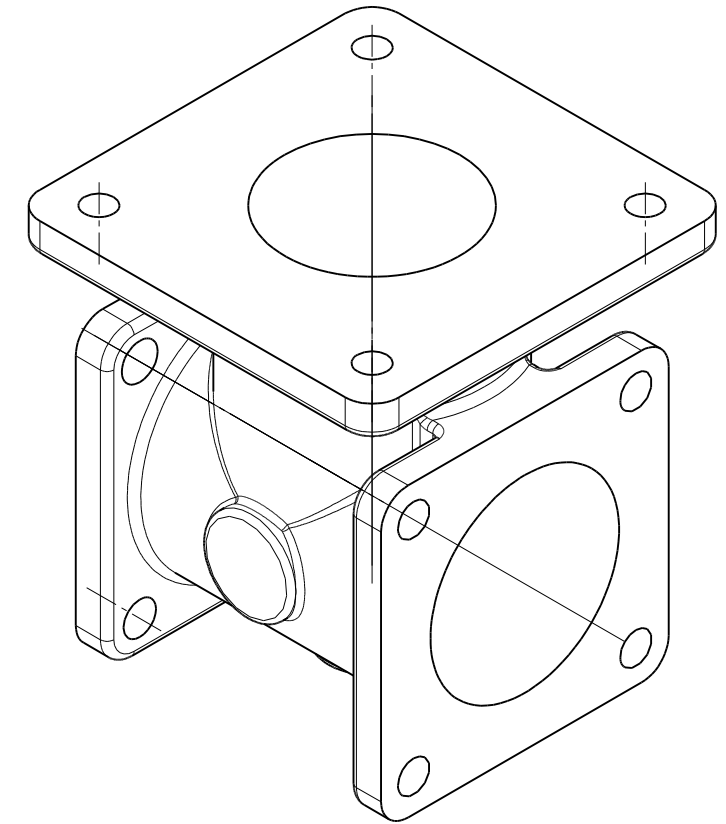
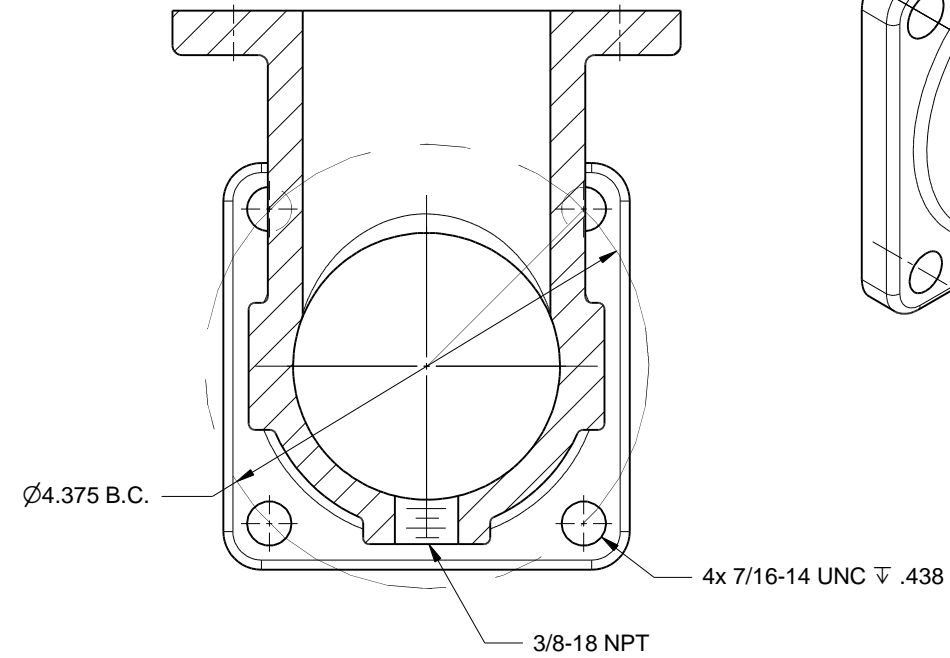
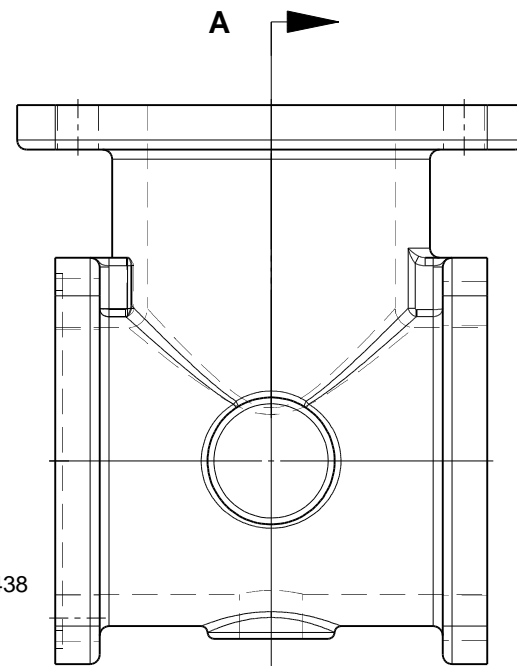
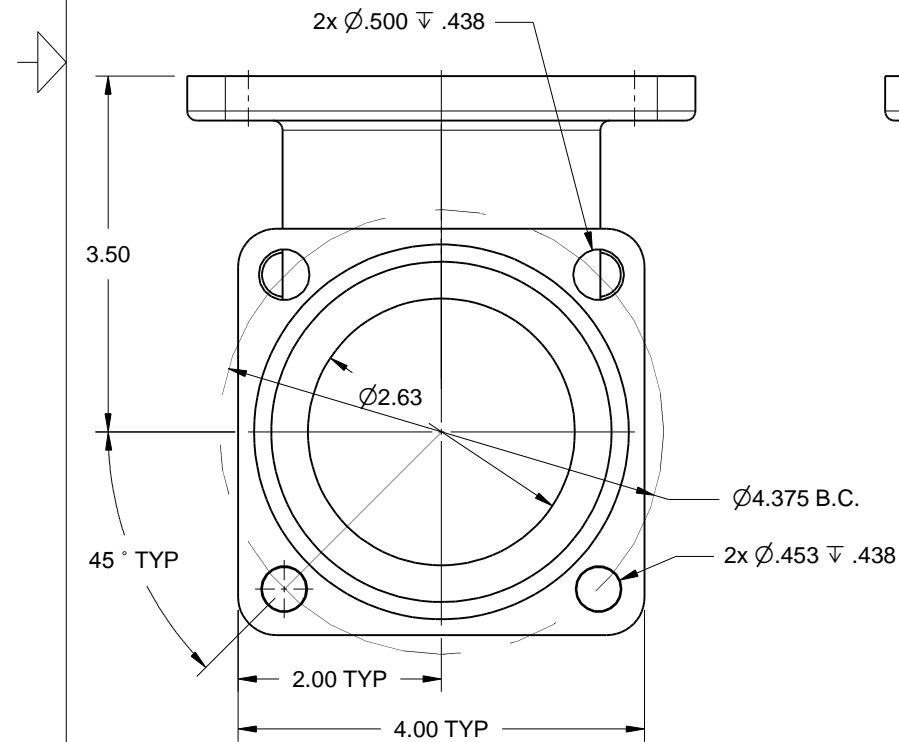
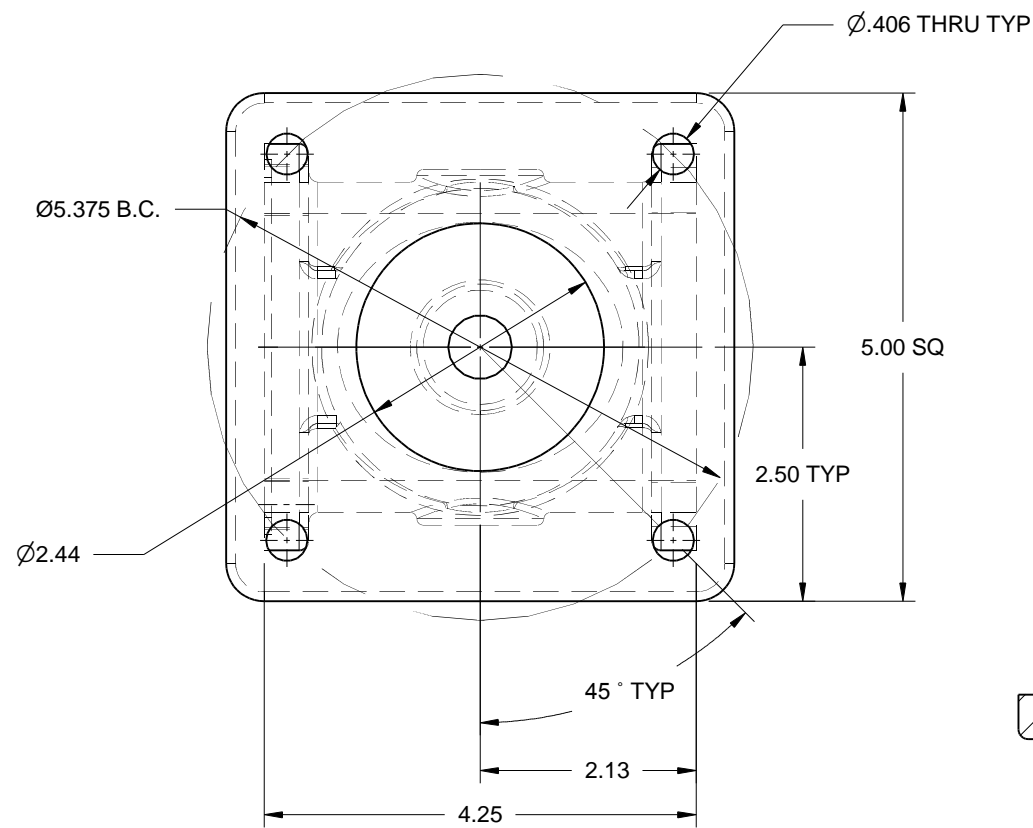

Volume = 35.9 in³
 Mass = 1.59 kg
 Surface Area = 223 in²

Section A-A

REMOVE ALL SHARP EDGES ALL DIMENSIONS ARE INCHES STANDARD TOLERANCES: .XX +/- .015 .XXX +/- .005 ANGLES +/- .5°		DRAWN MS	DATE 10/16/2013	TRIDENT EMERGENCY PRODUCTS, LLC <i>"Tomorrow's Ideas Delivered Today"</i> BODY, DISCHARGE MANIFOLD 2.5" ALUMINUM	
COPYRIGHT © DRAWING NOT TO BE REPRODUCED OR USED TO MAKE OTHER DRAWINGS OR MACHINERY		CHECKED	QA		
		MFG	APPROVED	DWG NO. 07.028.25	REV
				SCALE 1:2	SHEET 1 OF 1