

NOTES:

- 1. MATERIAL - A356-T6 ALUMINUM
- 2. HARD COAT ANODIZE

REVISIONS				
ZONE	REV	DESCRIPTION	DATE	APPROVED

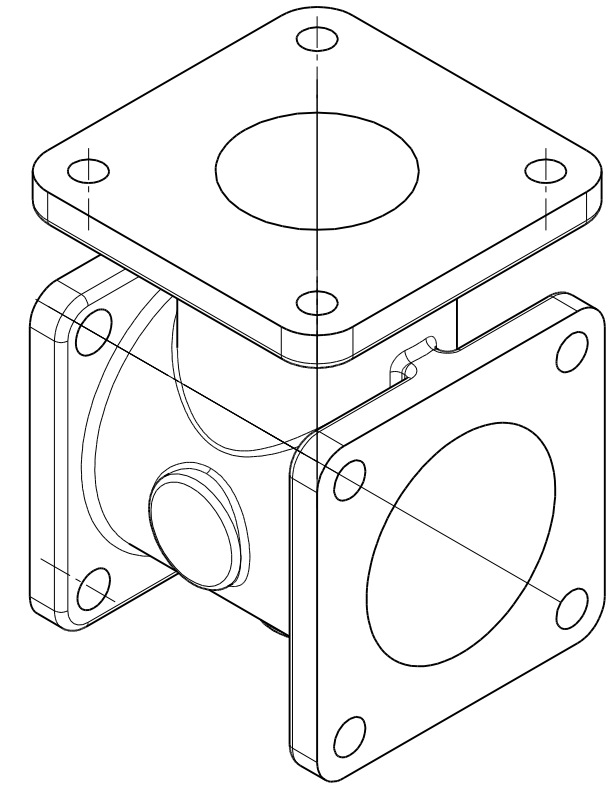
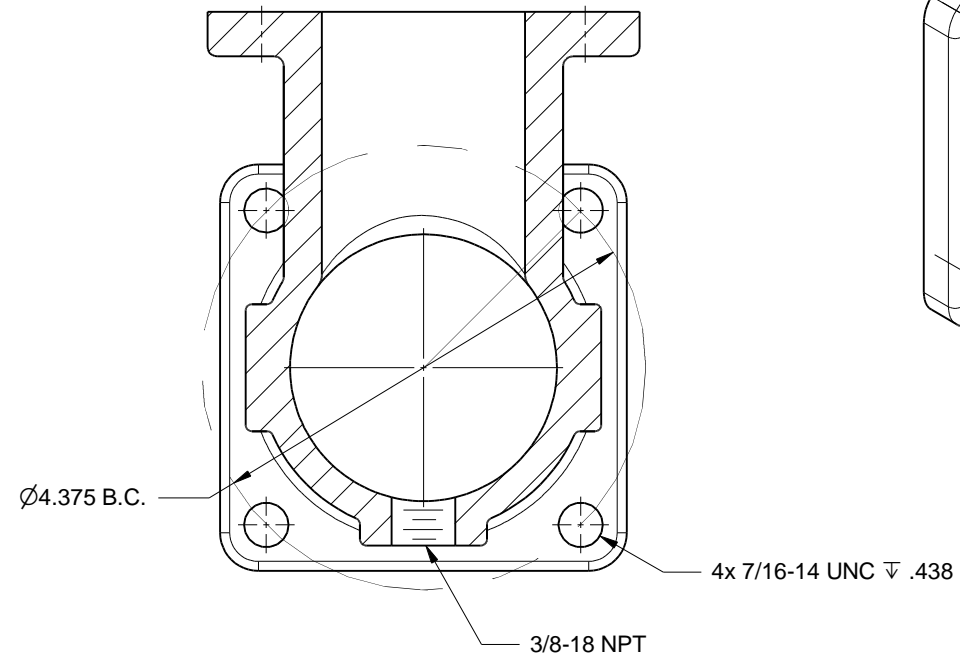
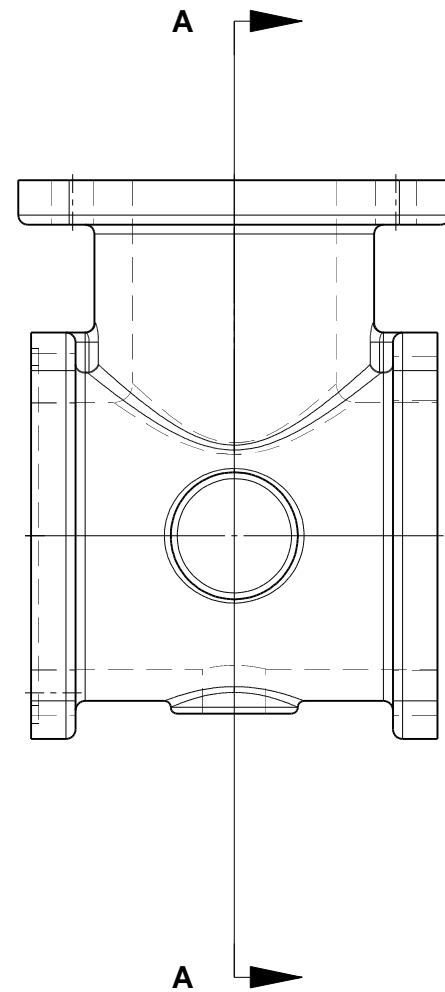
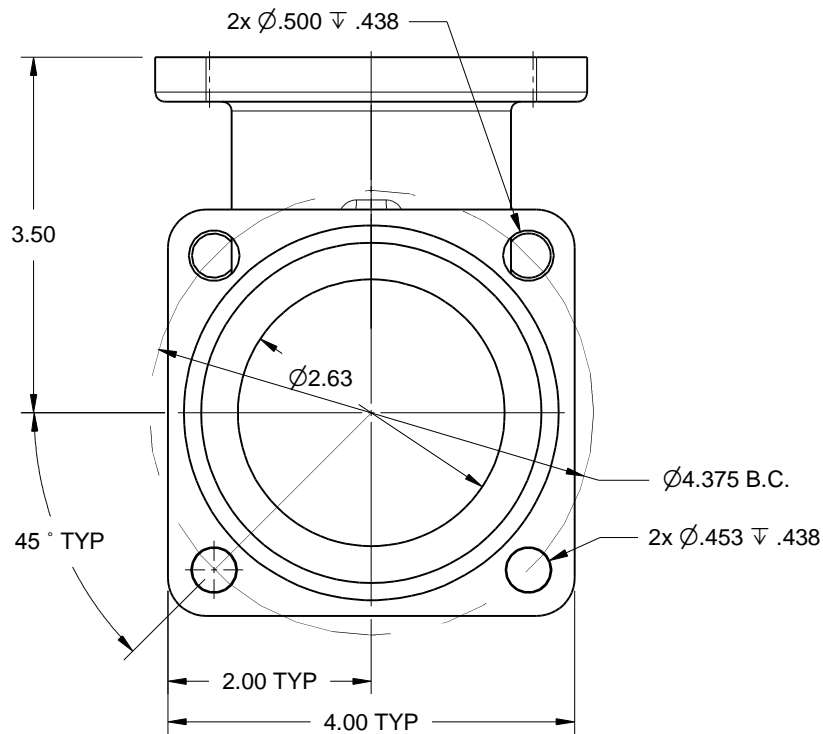
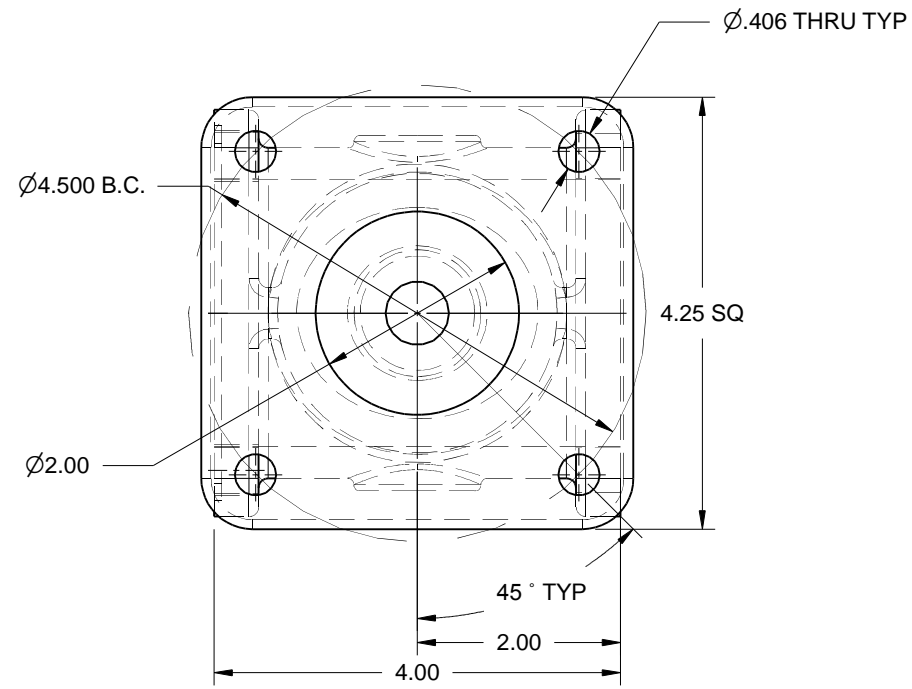

Volume = 27.8 in<sup>3</sup>  
 Mass = 1.23 kg  
 Surface Area = 172 in<sup>2</sup>

REMOVE ALL SHARP EDGES ALL DIMENSIONS ARE INCHES STANDARD TOLERANCES: .XX +/- .015 .XXX +/- .005 ANGLES +/- .5°		DRAWN	DATE	<b>TRIDENT EMERGENCY PRODUCTS, LLC</b> <i>"Tomorrow's Ideas Delivered Today"</i> <b>BODY, DISCHARGE MANIFOLD</b> <b>2" ALUMINUM</b>			
		MS	10/16/2013				
COPYRIGHT © DRAWING NOT TO BE REPRODUCED OR USED TO MAKE OTHER DRAWINGS OR MACHINERY		CHECKED		SIZE	FSCM NO.	DWG NO.	REV
		QA		<b>B</b>		07.028.20PC	
		MFG		SCALE	1:2	SHEET	1 OF 1
		APPROVED					