

NOTES:

- 1. MATERIAL - ALUMINUM
- 2. HARD COAT ANODIZE

REVISIONS				
ZONE	REV	DESCRIPTION	DATE	APPROVED

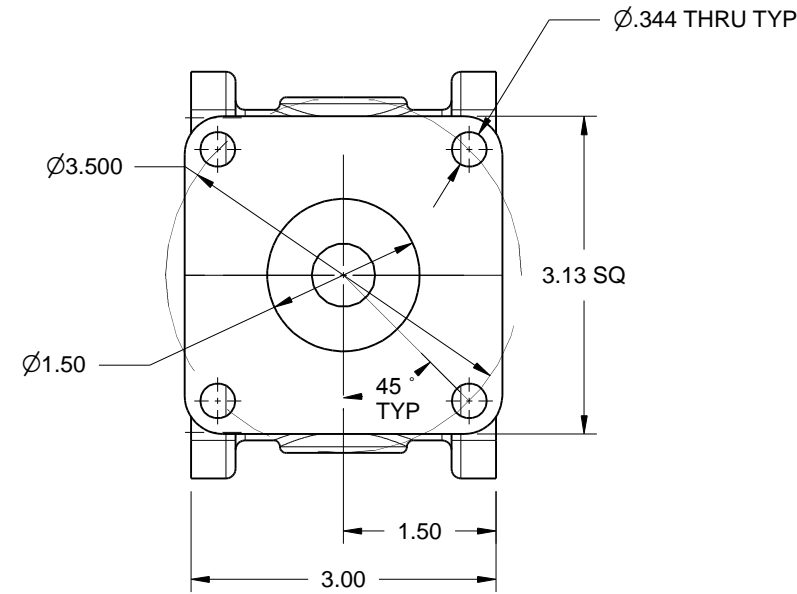

A

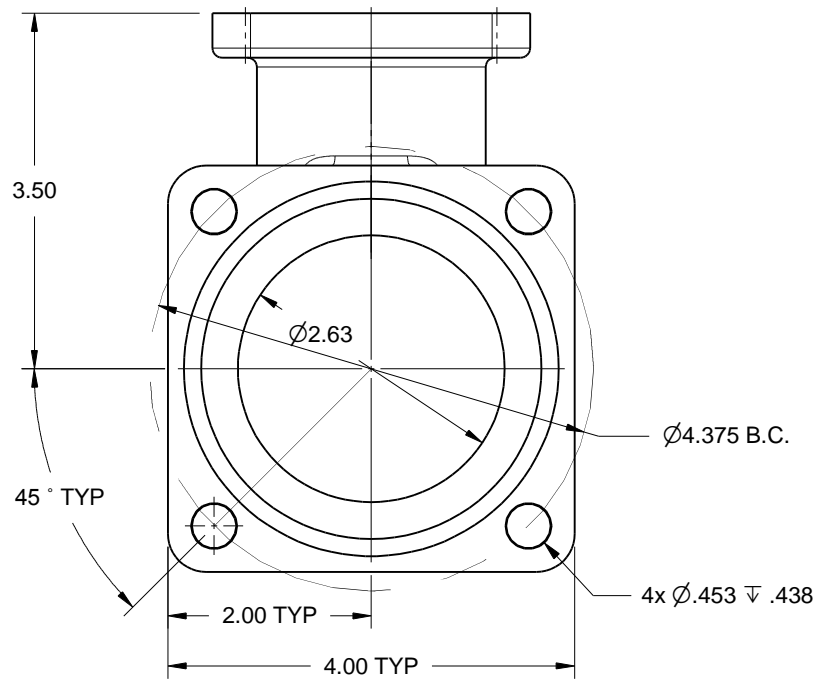
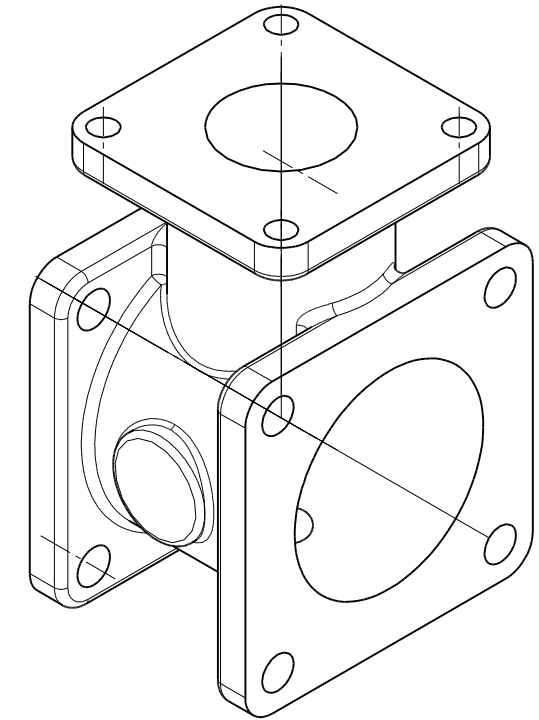

A

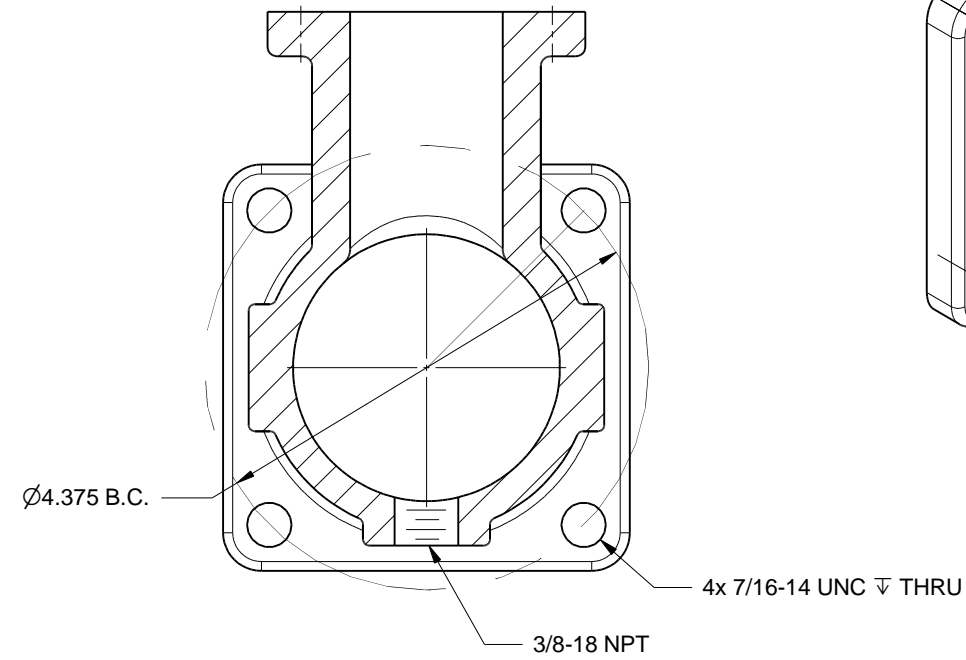

Section A-A

Volume = 21.3 in<sup>3</sup>  
 Mass = .94 kg  
 Surface Area = 133 in<sup>2</sup>

REMOVE ALL SHARP EDGES ALL DIMENSIONS ARE INCHES STANDARD TOLERANCES: .XX +/- .015 .XXX +/- .005 ANGLES +/- .5°	DRAWN MS	DATE 09/09/2013	<b>TRIDENT EMERGENCY PRODUCTS, LLC</b> <i>"Tomorrow's Ideas Delivered Today"</i> <b>BODY, DISCHARGE MANIFOLD</b> <b>1.5" ALUMINUM</b>		
	CHECKED	QA			
	COPYRIGHT © DRAWING NOT TO BE REPRODUCED OR USED TO MAKE OTHER DRAWINGS OR MACHINERY	MFG APPROVED		SIZE <b>B</b>	FSCM NO. DWG NO. 07.028.15
SCALE 1:2		SHEET 1 OF 1			