

REVISIONS				
REV	DESCRIPTION	DATE	DRAWN BY	APPROVED

(4) HOLES
.343 DIA THRU

Ø3.500

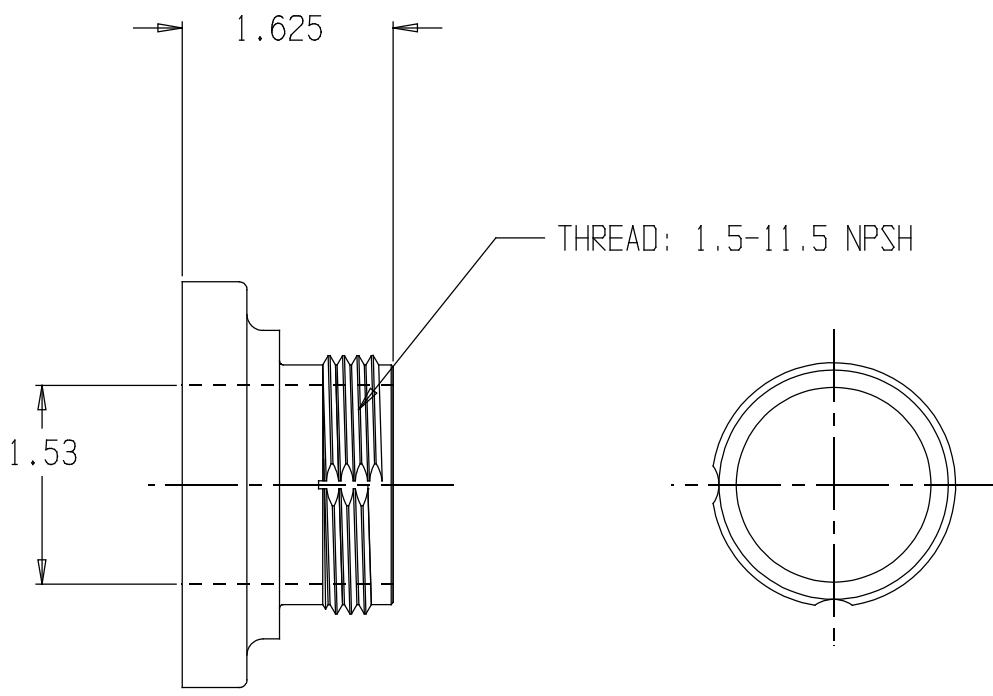
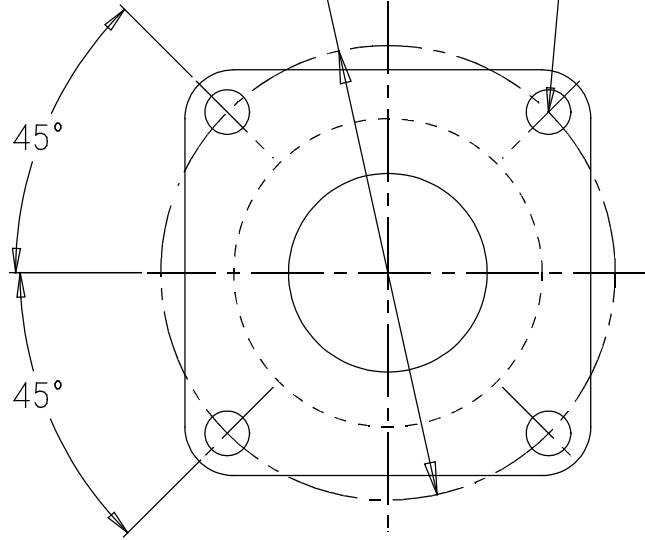

THREAD: 1.5-11.5 NPSH

- NOTES:
1) MATERIAL: ALUMINUM
2) HARD COAT ANODIZE



1.5 FLANGE X 1.5 MNPSH

REPORT ERRORS & CHANGES
REMOVE ALL SHARP EDGES
UNLESS OTHERWISE SPECIFIED
ALL DIMENSIONS ARE IN INCHES

STANDARD TOLERANCES:
DECIMALS
ANGLES

.XX ± .030 ± 1/2°
.XXX ± .015

COPYRIGHT ©
DRAWING NOT TO BE REPRODUCED OR USED TO
MAKE OTHER DRAWINGS OR MACHINERY

SIZE B DWG NO. 09.065.4PC REV .

DRAWN BY: MJD
CHECKED BY: MS

DATE 08-09-2013 SCALE 1:1

SHEET 1 OF 1