

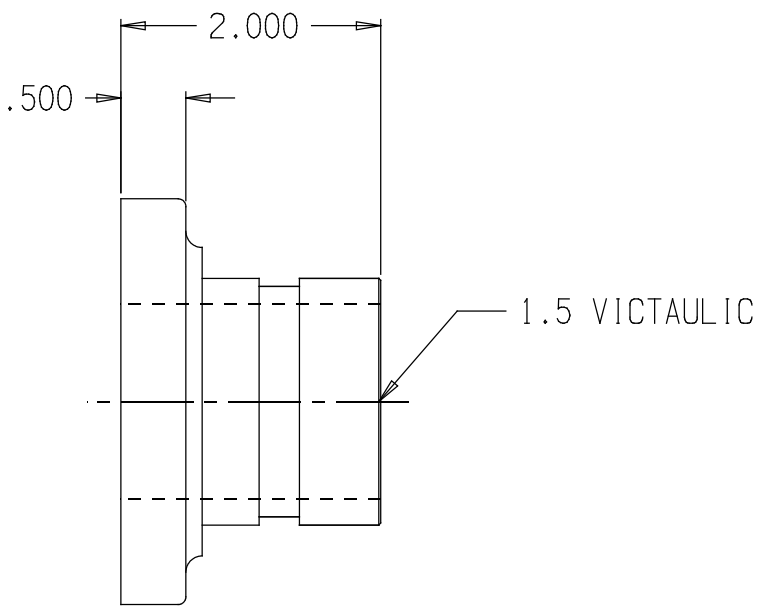

REVISIONS				
REV	DESCRIPTION	DATE	DRAWN BY	APPROVED

(4) HOLES  
.343 DIA THRU

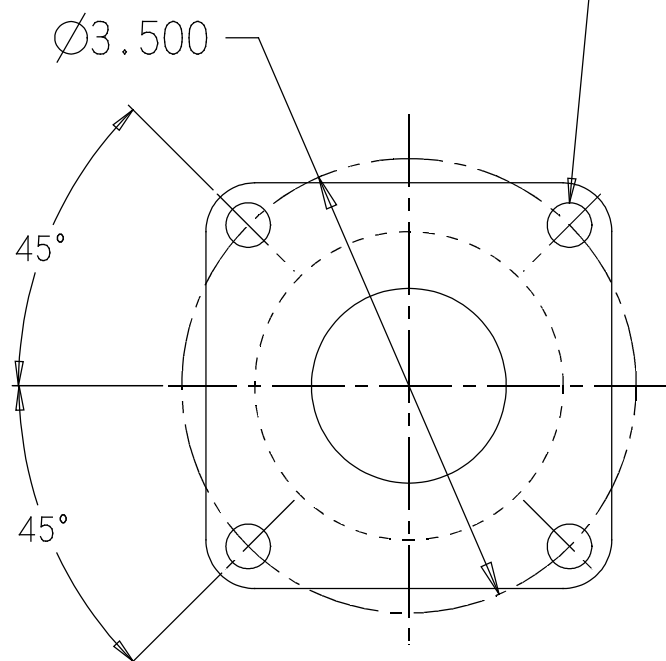

NOTES:  
1) MATERIAL: ALUMINUM  
2) HARD COAT ANODIZE

 <b>EMERGENCY PRODUCTS, LLC</b>	1.5 FLANGE X 1.5 VIC			
	<small>REPORT ERRORS &amp; CHANGES REMOVE ALL SHARP EDGES UNLESS OTHERWISE SPECIFIED ALL DIMENSIONS ARE IN INCHES</small>	<small>STANDARD TOLERANCES:</small> .XX ± .030 .XXX ± .015	<small>DECIMALS</small> ± 1/2"	<small>ANGLES</small>
<small>COPYRIGHT © DRAWING NOT TO BE REPRODUCED OR USED TO MAKE OTHER DRAWINGS OR MACHINERY</small>	SIZE B	DWG NO. 09.065.1PC	REV 	
<small>DRAWN BY</small> MS <small>CHECKED BY</small> MS <small>DATE</small> 07-24-2013	SCALE 1:1	SHEET 1 OF 1		