

| REVISIONS | | | | |
|-----------|-------------|------|----------|----------|
| REV | DESCRIPTION | DATE | DRAWN BY | APPROVED |
| | | | | |

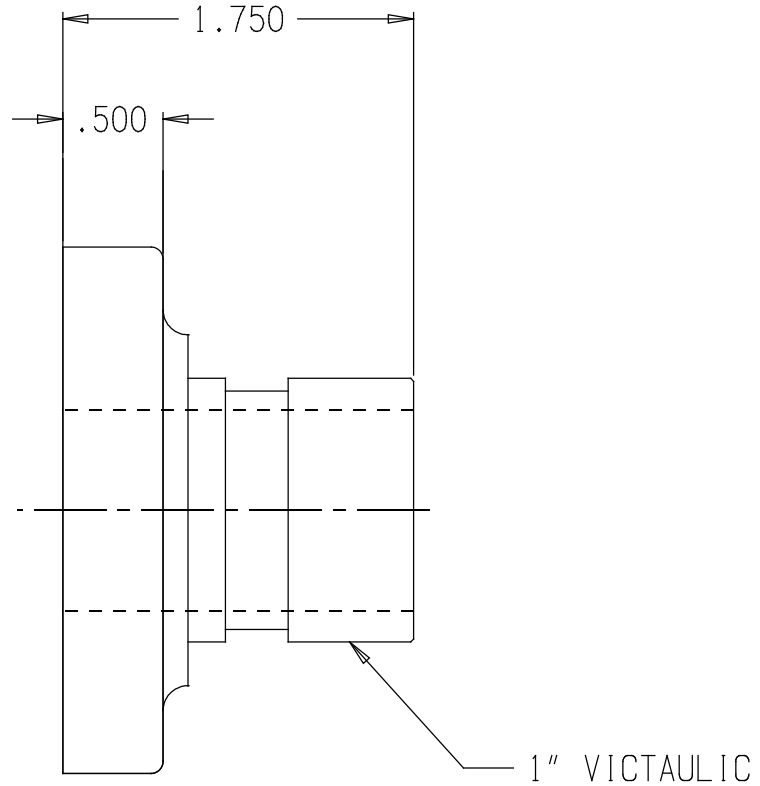

- NOTES:
 1) MATERIAL: ALUMINUM
 2) HARD COAT ANODIZE

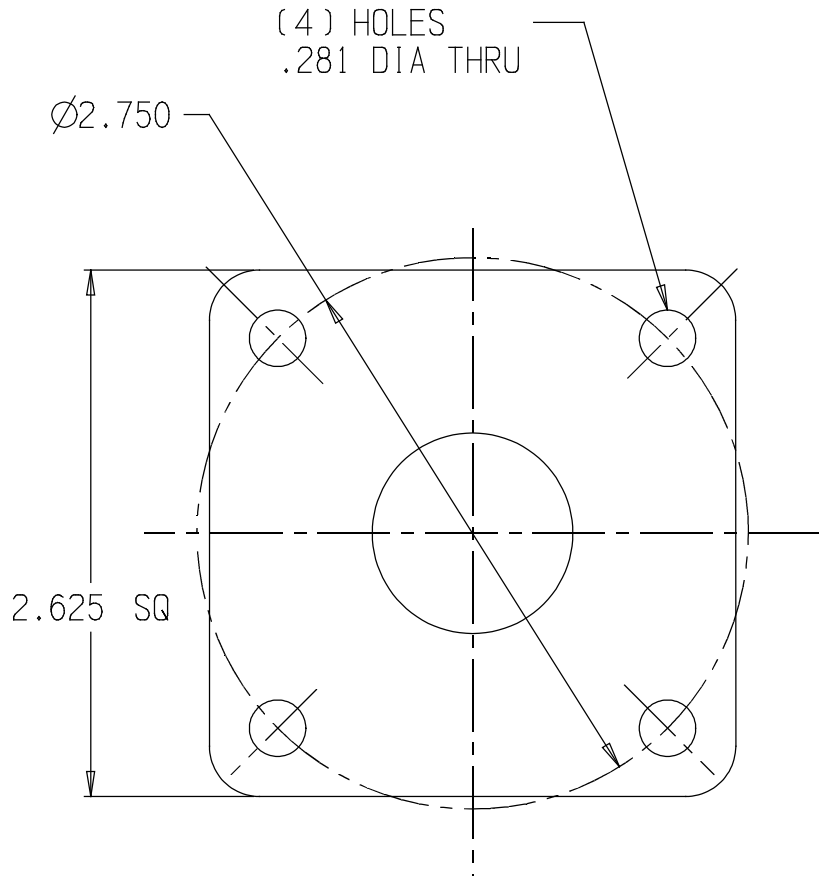

1" FLANGE X 1" VIC

REPORT ERRORS & CHANGES
 REMOVE ALL SHARP EDGES
 UNLESS OTHERWISE SPECIFIED
 ALL DIMENSIONS ARE IN INCHES

STANDARD TOLERANCES:

| | |
|-------------|--------|
| DECIMALS | ANGLES |
| .XX ± .030 | ± 1/2° |
| .XXX ± .015 | |

COPYRIGHT ©
 DRAWING NOT TO BE REPRODUCED OR USED TO
 MAKE OTHER DRAWINGS OR MACHINERY

| | | |
|------------|-----|-----------------|
| DRAWN BY | MDD | DATE 08-01-2013 |
| CHECKED BY | MS | |

| | | |
|-----------|-----------------------|-----|
| SIZE A | DWG NO. 09.064-1PC | REV |
| SCALE 1:1 | SHEET 1 OF 1 | |