

REVISIONS				
REV	DESCRIPTION	DATE	DRAWN BY	APPROVED

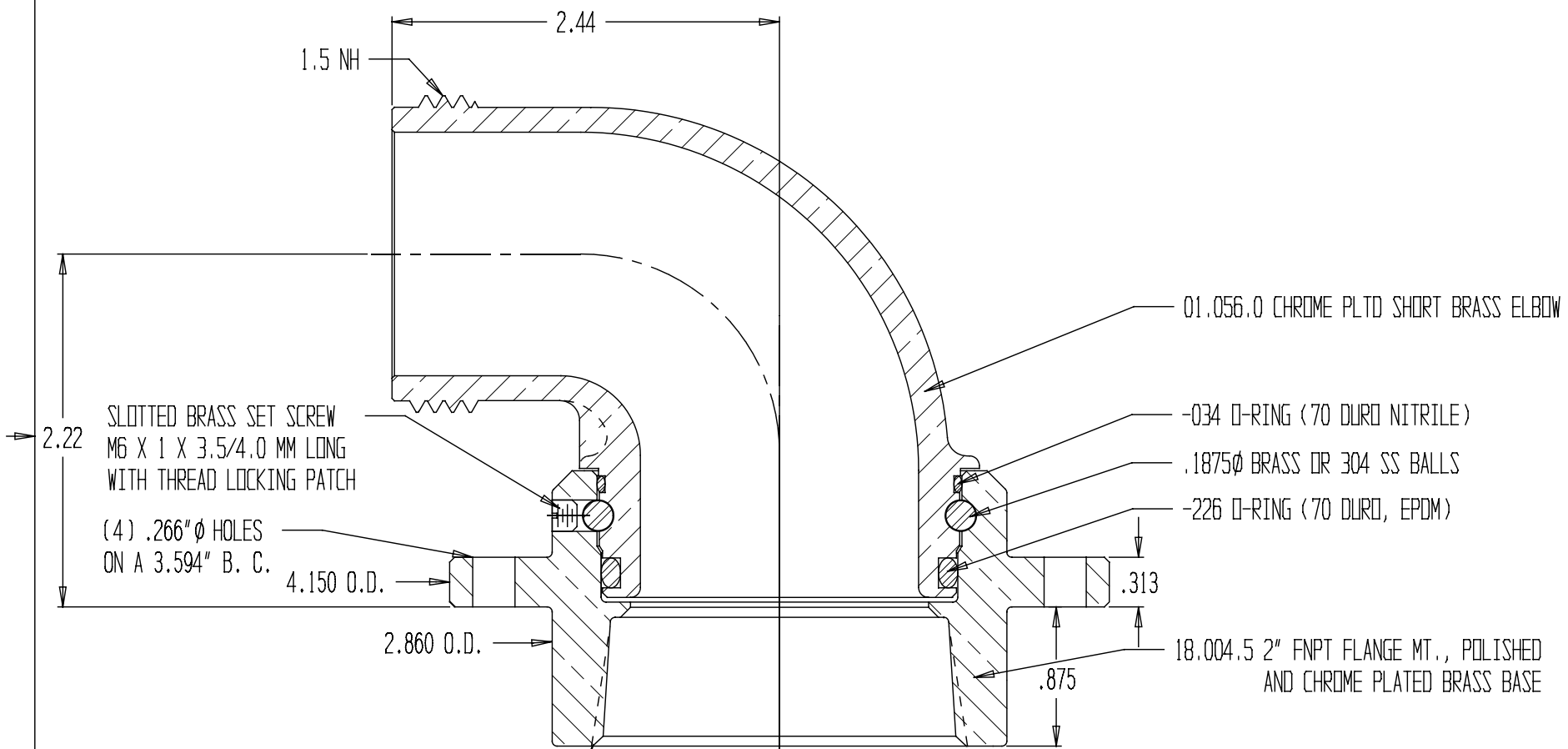

1.5NH X 2" NPT CHR. FLANGE ELBOW

REPORT ERRORS & CHANGES  
REMOVE ALL SHARP EDGES  
UNLESS OTHERWISE SPECIFIED  
ALL DIMENSIONS ARE IN INCHES

STANDARD TOLERANCES:

DECIMALS	ANGLES
.XX $\pm$ .030	$\pm$ 1/2 $^\circ$
.XXX $\pm$ .015	

COPYRIGHT © DRAWING NOT TO BE REPRODUCED OR USED TO MAKE OTHER DRAWINGS OR MACHINERY		SIZE A	DWG NO. 01.055.29	REV .
DRAWN BY MS	CHECKED BY MS	DATE 06/15/2006	SCALE 1:1	SHEET 1 OF 1