

REVISIONS				
REV	DESCRIPTION	DATE	DRAWN BY	APPROVED

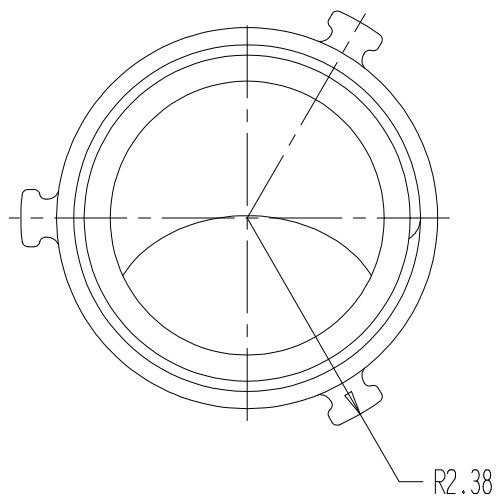
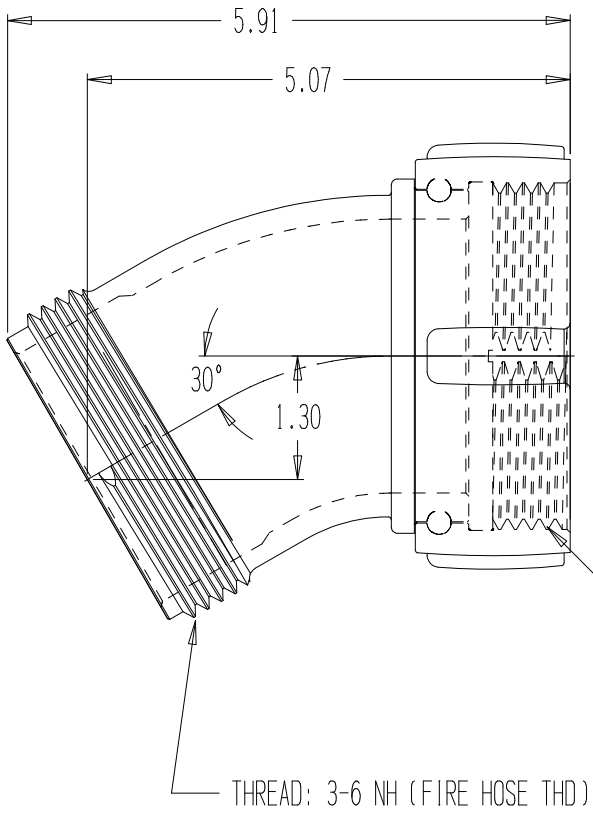

3" FEMALE NH SWIVEL  
 THREAD: 3-6 NH (FIRE HOSE THD)

THREAD: 3-6 NH (FIRE HOSE THD)

NOTES:

- 1) CHROME PLATED
- 2) MATERIAL: BRASS
- 3) BALL MATERIAL: STAINLESS
- 4) RUBBER WASHER INCLUDED AND INSTALLED



ADAPTER, 3 NH X 30°

REPORT ERRORS & CHANGES  
 REMOVE ALL SHARP EDGES  
 UNLESS OTHERWISE SPECIFIED  
 ALL DIMENSIONS ARE IN INCHES

STANDARD TOLERANCES:

DECIMALS	ANGLES
.XX ± .030	± 1/2°
.XXX ± .015	

DRAWING NOT TO BE REPRODUCED OR USED TO MAKE OTHER DRAWINGS OR MACHINERY		COPYRIGHT ©	SIZE A	DWG NO.	01.016.20PC	REV
DRAWN BY	MS	DATE	SCALE			
CHECKED BY	MS	08/17/2004	1:2			
					SHEET	1 OF 1