

PART NO.	THREAD FORM
01.S02.0	3.095 X 6 TPI
01.S02.1	3.078 X 6 TPI
01.S02.2	3.062 X 6 TPI
01.S02.4	3.040 X 8 TPI
01.S02.5	3.125 X 7.5 TPI
01.S02.6	3.031 X 7 TPI
01.S02.7	3.062 X 7 TPI
01.S02.8	SEE DWG 2 OF 3
01.S02.9	3.340 X 6 TPI
01.S02.10	3.125 X 7 TPI
01.S02.11	3.00 X 8 TPI
01.S02.12	3.230 X 5 TPI
01.S02.13	SEE DWG 2 OF 2
01.S02.14	2.953 X 7.5TPI
01.S02.15	3.175 X 6 TPI
01.S02.16	3.125 X 5 TPI
01.S02.17	2.990 X 7.5TPI
01.S02.18	2.990 X 8 TPI
01.S02.19	3.250 X 6 TPI
01.S02.20	3.093 X 8 TPI
01.S02.21	3.250 X 5 TPI
01.S02.22	3.093 X 6 TPI
01.S02.23	2.968 X 8 TPI
01.S02.24	3.062 X 8 TPI
01.S02.25	3.078 X 8 TPI
01.S02.27	3.125 X 5 TPI
01.S02.28	3.077 X 7 TPI
01.S02.29	3.125 X 6DL TPI
01.S02.34	3.250 X 5 TPI

REVISIONS				
REV	DESCRIPTION	DATE	DRAWN BY	APPROVED

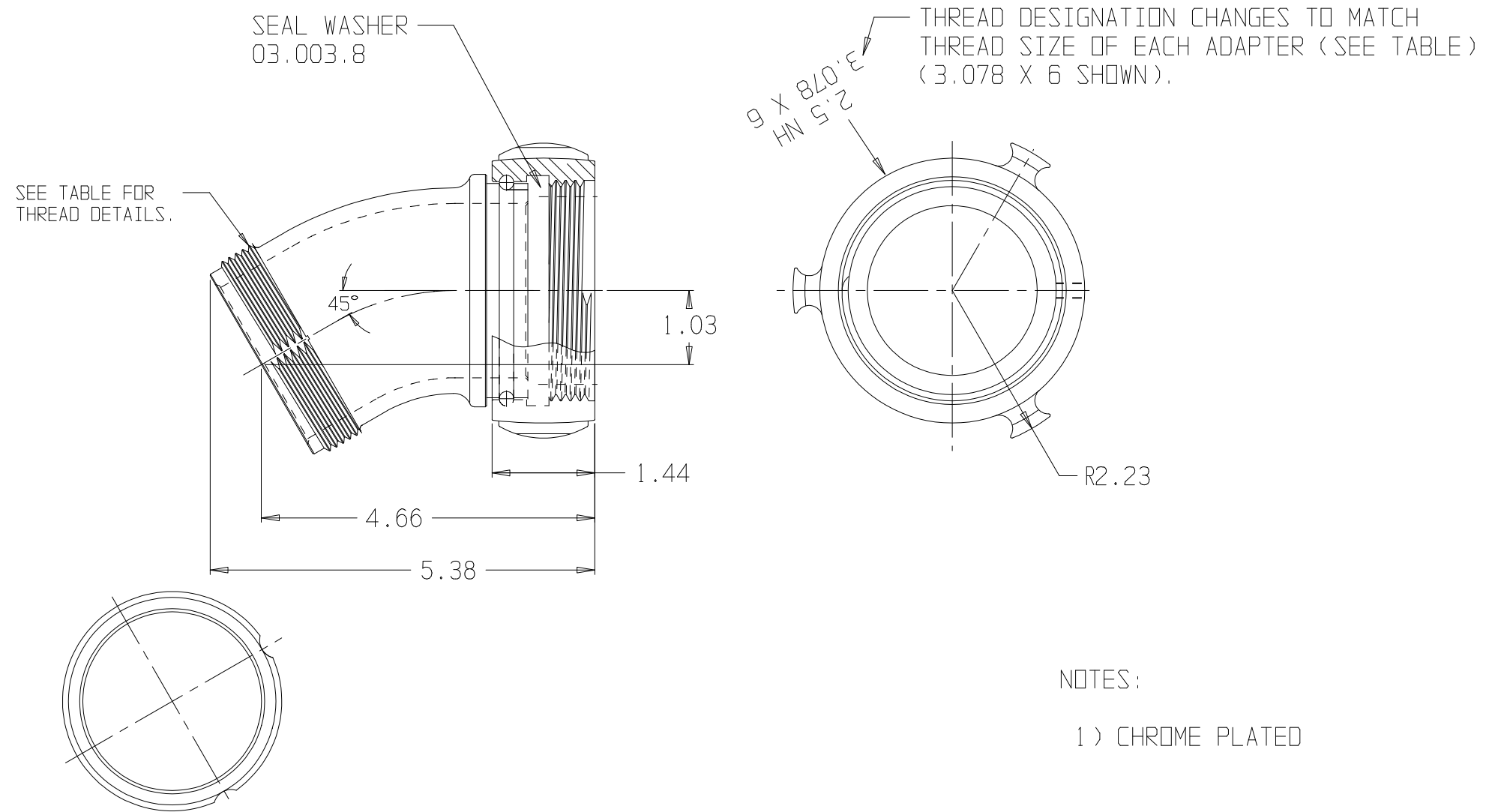
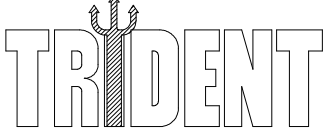

 EMERGENCY PRODUCTS, LLC	SPCL. THD 45° ADPTR.		
	REPORT ERRORS & CHANGES REMOVE ALL SHARP EDGES UNLESS OTHERWISE SPECIFIED ALL DIMENSIONS ARE IN INCHES	STANDARD TOLERANCES: DECIMALS .XX ± .030 .XXX ± .015	ANGLES ± 1/2°
COPYRIGHT © DRAWING NOT TO BE REPRODUCED OR USED TO MAKE OTHER DRAWINGS OR MACHINERY	SIZE B	DWG NO. 01.S02.XXPC	REV
DRAWN BY CHECKED BY	MS MS	DATE 10/24/2003	SCALE 1:2 SHEET 1 OF 3