

REVISIONS				
REV	DESCRIPTION	DATE	DRAWN BY	APPROVED

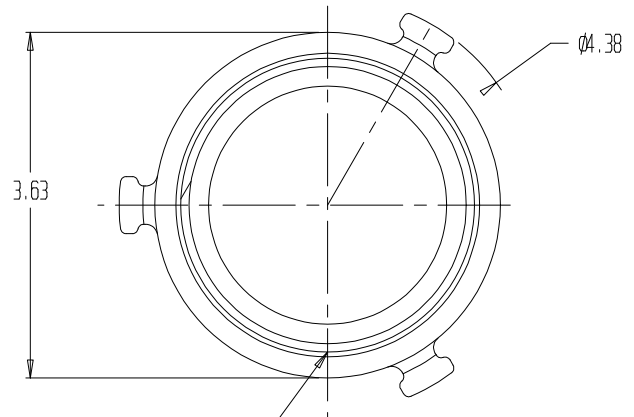
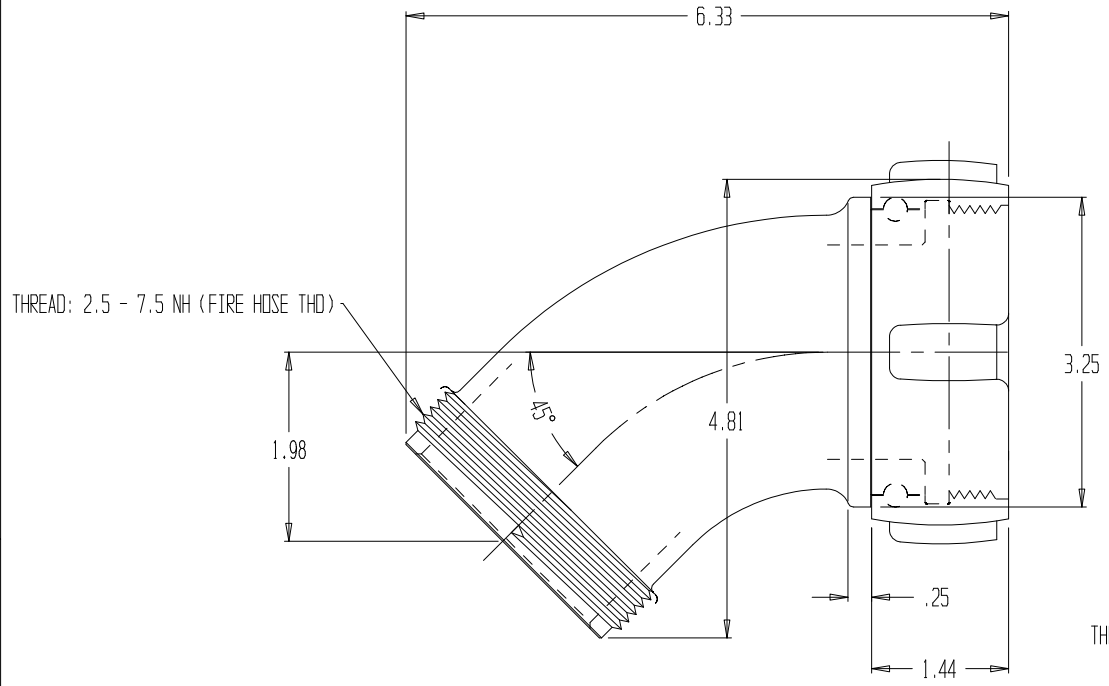

THREAD: 2.5 - 7.5 NH (FIRE HOSE THD)

NOTES:

- 1) CHROME PLATED
- 2) MATERIAL: BRASS
- 3) RUBBER WASHER INCLUDED
- 4) BALL MATERIAL: BRASS

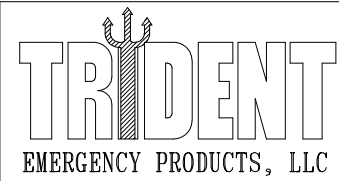
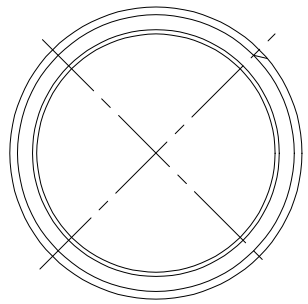

ADAPTER, 2-1/2 NH X 45°

REPORT ERRORS & CHANGES
REMOVE ALL SHARP EDGES
UNLESS OTHERWISE SPECIFIED
ALL DIMENSIONS ARE IN INCHES

STANDARD TOLERANCES:

DECIMALS	ANGLES
.XX ± .030	± 1/2°
.XXX ± .015	

COPYRIGHT ©
DRAWING NOT TO BE REPRODUCED OR USED TO
MAKE OTHER DRAWINGS OR MACHINERY

DRAWN BY	001	DATE	08/27/2000
CHECKED BY	001		

SIZE .
A

DWG NO. 01.002.0PC

REV

SCALE 1:2

SHEET 1 OF 1