

REVISIONS				
REV	DESCRIPTION	DATE	DRAWN BY	APPROVED

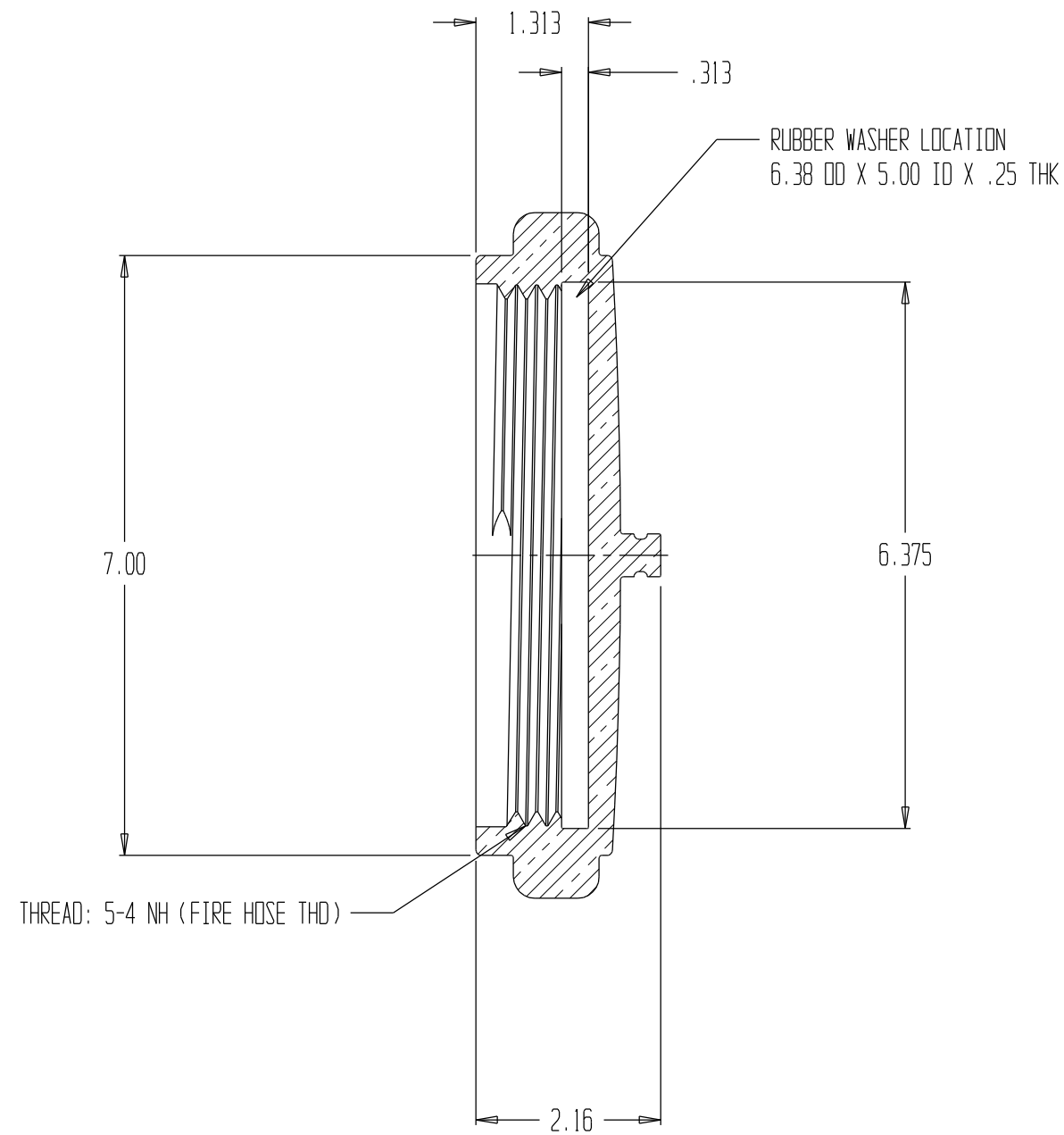

SECTION A-A

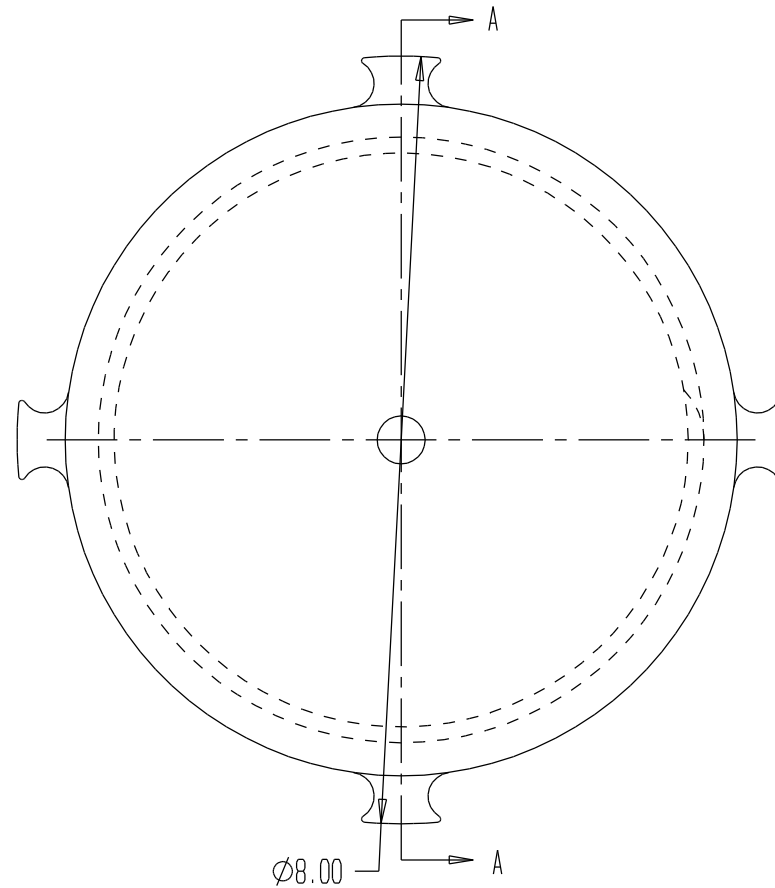

- NOTES:
1. MATERIAL - BRASS
 2. BLUFF AND POLISH ALL EXTERNAL SURFACES TO A MIRROR FINISH
 3. CHROME PLATE ALL SURFACES PER TRIDENT SPECIFICATION 99.003.0
 4. MIN HYDROSTATIC TEST PRESSURE: 600 PSI

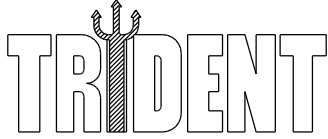
 EMERGENCY PRODUCTS, LLC	CAP, 5" NH, ROCKER LUGS		
	<small>REPORT ERRORS & CHANGES REMOVE ALL SHARP EDGES UNLESS OTHERWISE SPECIFIED ALL DIMENSIONS ARE IN INCHES</small>	<small>STANDARD TOLERANCES:</small> <small>DECIMALS</small> <small>.XX ± .030</small> <small>.XXX ± .015</small>	<small>ANGLES</small> <small>± 1/2°</small>
<small>COPYRIGHT © DRAWING NOT TO BE REPRODUCED OR USED TO MAKE OTHER DRAWINGS OR MACHINERY</small>	<small>SIZE</small> B	<small>DWG NO.</small> 01.009.6PC	<small>REV</small>
<small>DRAWN BY</small> MS <small>CHECKED BY</small> MS	<small>DATE</small> 06/04/2002	<small>SCALE</small> 1:2	<small>SHEET</small> 1 OF 1