

REVISIONS				
REV	DESCRIPTION	DATE	DRAWN BY	APPROVED

THREAD: 3-6 NH (FIRE HOSE THD)

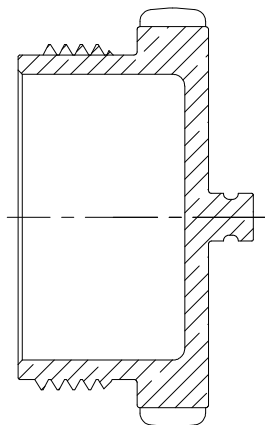

SECTION A-A

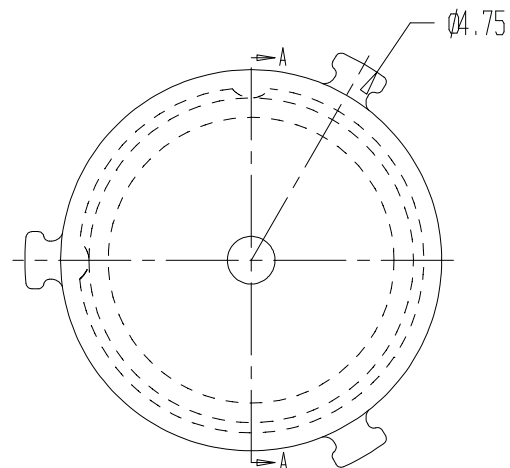
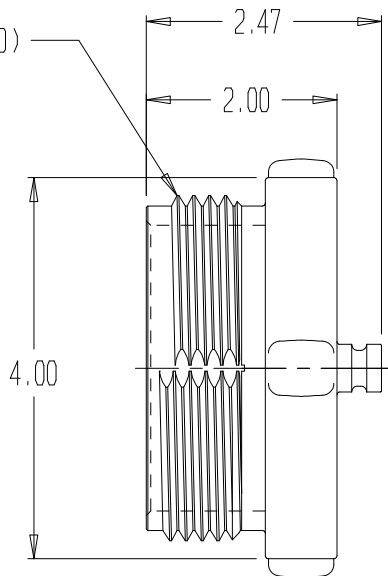

S-HOOK (BEFORE CRIMP)
MAT'L: STAINLESS

NOTES:

- 1) CHROME PLATED
- 2) MATERIAL: BRASS
- 3) 12" L X .250" Ø BALL BEAD CHAIN INCLUDED IN ASSEMBLY, BUT NOT SHOWN (CHROME PLATED BRASS)

U.S. PATENT
7,416,223



PLUG ASSY, 3" NH

REPORT ERRORS & CHANGES
REMOVE ALL SHARP EDGES
UNLESS OTHERWISE SPECIFIED
ALL DIMENSIONS ARE IN INCHES

STANDARD TOLERANCES:
DECIMALS .XX ± .030
 .XXX ± .015
ANGLES ± 1/2°

COPYRIGHT ©
DRAWING NOT TO BE REPRODUCED OR USED TO
MAKE OTHER DRAWINGS OR MACHINERY

DRAWN BY	MS	DATE 03/19/2002
CHECKED BY	MS	

SIZE	A
SCALE	1:2

DWG NO.	01.022.0PC
SHEET	1 OF 1

REV	.
-----	---