

REVISIONS				
REV	DESCRIPTION	DATE	DRAWN BY	APPROVED
.
.

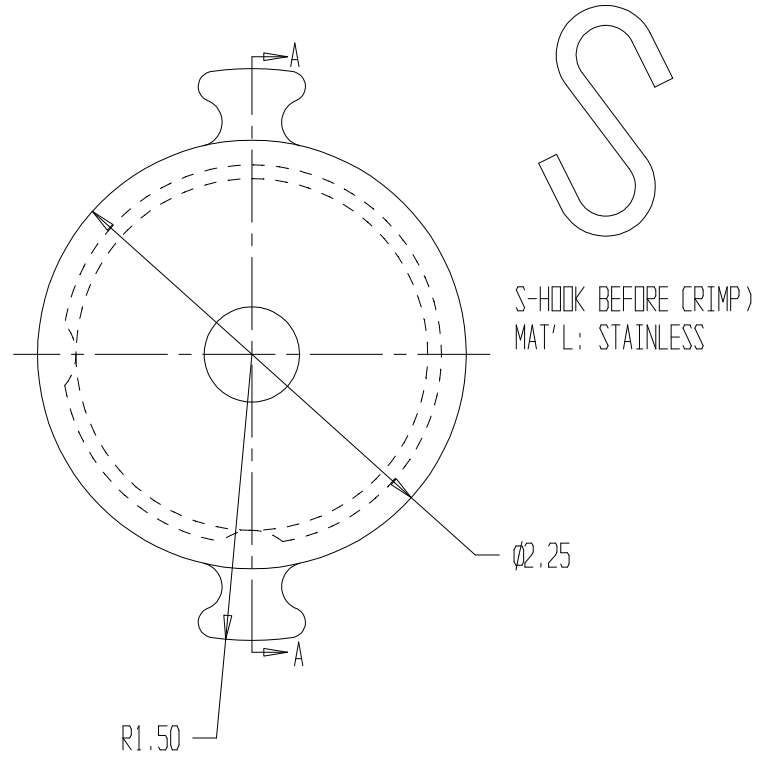

NOTES:

- 3) CHROME PLATED
- 4) MATERIAL: BRASS
- 5) 12" L X .250" \varnothing BALL BEAD CHAIN INCLUDED IN ASSEMBLY, BUT NOT SHOWN (CHROME PLATED BRASS)

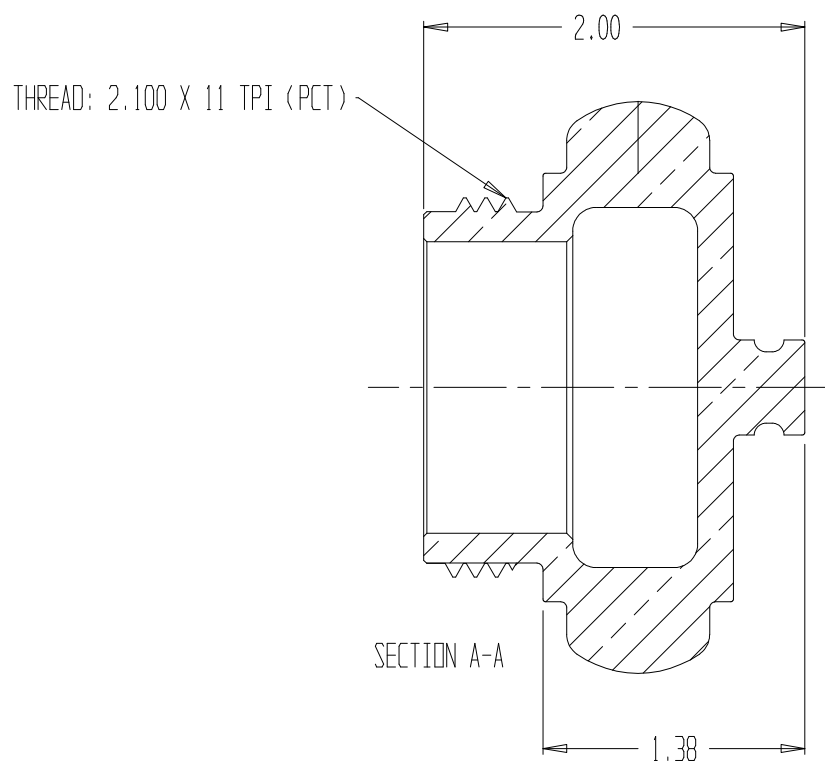

PLUG, 2.100x11 (CHROME)

REPORT ERRORS & CHANGES
REMOVE ALL SHARP EDGES
UNLESS OTHERWISE SPECIFIED
ALL DIMENSIONS ARE IN INCHES

STANDARD TOLERANCES:

DECIMALS	ANGLES
.XX \pm .030	\pm 1/2°
.XXX \pm .015	

COPYRIGHT © DRAWING NOT TO BE REPRODUCED OR USED TO MAKE OTHER DRAWINGS OR MACHINERY		SIZE A	DWG NO.	REV
DRAWN BY MS	CHECKED BY MS	DATE 04/30/2009	01.132.0PC	
SCALE 1:1		SHEET 1 OF 1		