

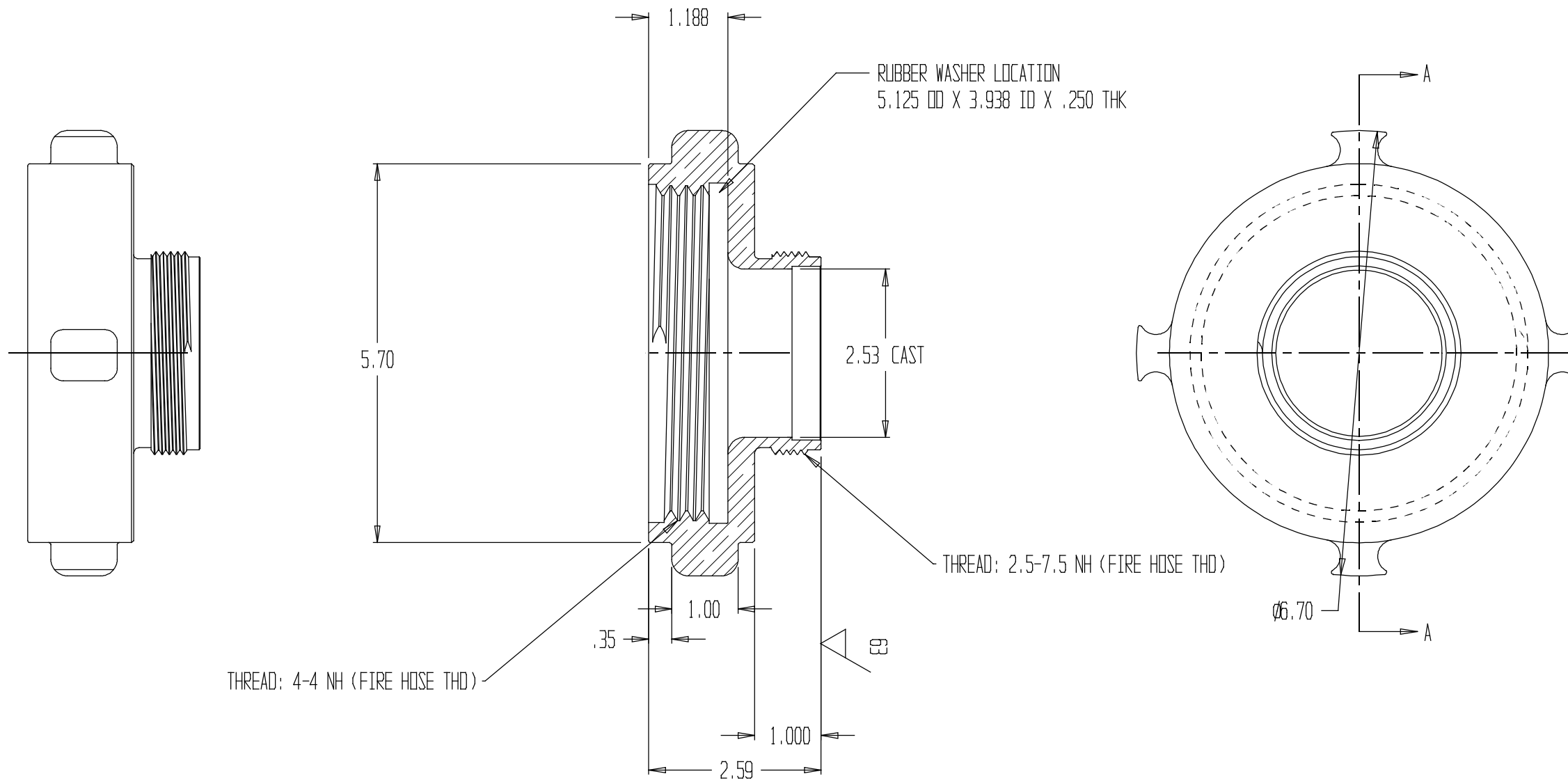

- NOTES:
- 1) BUFF & POLISH ALL EXTERIOR SURFACES TO A MIRROR FINISH
 - 2) CHROME PLATE
 - 3) MATERIAL: BRASS
 - 4) 70 DUROMETER SHORE A NEOPRENE RUBBER WASHER INCLUDED IN ASSEMBLY

REVISIONS				
REV	DESCRIPTION	DATE	DRAWN BY	APPROVED



THREAD: 4-4 NH (FIRE HOSE THD)

SECTION A-A

 EMERGENCY PRODUCTS, LLC	ADAPTER, 4" FNH x 2.5" MNH	
	<small>REPORT ERRORS & CHANGES REMOVE ALL SHARP EDGES UNLESS OTHERWISE SPECIFIED ALL DIMENSIONS ARE IN INCHES</small>	<small>STANDARD TOLERANCES:</small> <small>DECIMALS .XX ± .030 .XXX ± .015</small> <small>ANGLES ± 1/2°</small>
<small>COPYRIGHT © DRAWING NOT TO BE REPRODUCED OR USED TO MAKE OTHER DRAWINGS OR MACHINERY</small>	<small>SIZE B</small>	<small>DWG NO. 01.065.0PC</small>
<small>DRAWN BY MS CHECKED BY MS</small>	<small>DATE 09/11/2002</small>	<small>SCALE 1:2</small>
<small>SHEET 1 OF 1</small>		<small>REV .</small>