

PART NO.	THREAD FORM
01.S68.0	3.234 x 6 TPI
01.S68.1	3.078 X 6 TPI
01.S68.2	3.00 X 8 TPI
01.S68.3	3.00 X 8 TPI
01.S68.4	3.063 X 6 TPI
01.S68.5	3.156 X 6 TPI
01.S68.6	3.078 X 8 TPI
01.S68.7	3.055 X 6 TPI
01.S68.8	2.843 X 8 TPI
01.S68.9	3.125 X 7.5 TPI
01.S68.10	3.328 X 8 TPI
01.S68.11	3.125 X 6 TPI
01.S68.12	3.040 X 8 TPI
01.S68.13	3.030 X 8 TPI
01.S68.14	3.06 X 7 TPI
01.S68.15	3.125 X 5 TPI
01.S68.16	3.165 X 7.5TPI
01.S68.17	3.250 X 6 TPI
01.S68.18	3.073 X 6 TPI
01.S68.19	3.250 X 5 TPI
01.S68.20	3.187 X 6 TPI
01.S68.21	3.093 X 6 TPI
01.S68.22	2.5 NH
01.S68.23	3.218 X 6 TPI
01.S68.24	2.950 X 8 TPI
01.S68.26	3.031 X 7 TPI
01.S68.27	2.990 X 8 TPI
01.S68.28	3.230 X 5 TPI
01.S68.29	
01.S68.30	
01.S68.31	2.841 X 8 TPI
01.S68.32	3.250 X 5 TPI
01.S68.XX	
01.S68.XX	
01.S68.XX	
01.S68.XX	
01.S68.XX	
01.S68.XX	

REVISIONS				
REV	DESCRIPTION	DATE	DRAWN BY	APPROVED

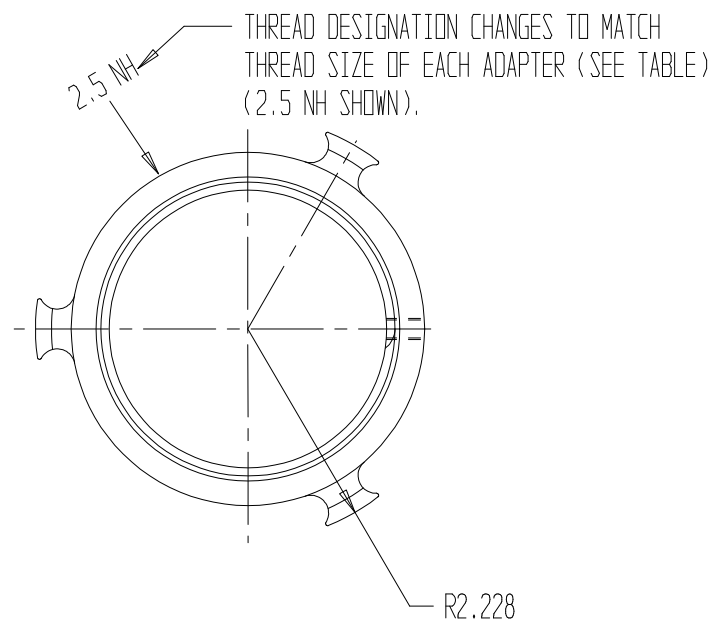
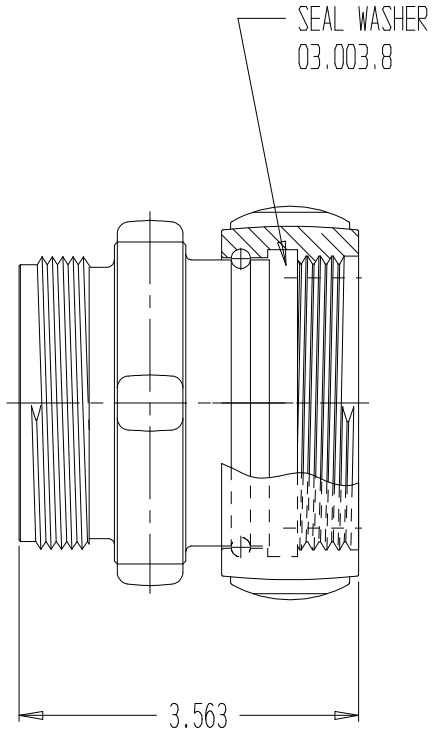

	SPCL. THD 2.5" SUCT. ADPTR.		
	REPORT ERRORS & CHANGES REMOVE ALL SHARP EDGES UNLESS OTHERWISE SPECIFIED ALL DIMENSIONS ARE IN INCHES	STANDARD TOLERANCES: DECIMALS .XX ± .030 .XXX ± .015	ANGLES ± 1/2°
COPYRIGHT © DRAWING NOT TO BE REPRODUCED OR USED TO MAKE OTHER DRAWINGS OR MACHINERY	SIZE B	DWG NO. 01.S68.XXPC	REV
DRAWN BY MS CHECKED BY MS	DATE 10/24/2003	SCALE 1:2	SHEET 1 OF 1