

PART NO.	THREAD FORM	MALE THREAD
01.S08.0	3.063 X 6 TPI	X 1.5 NH
01.S08.1	3.00 X 8 TPI	X 1.5 NH
01.S08.2	3.328 X 8 TPI	X 1.5 NH
01.S08.3	3.125 X 6 TPI	X 1.5 NH
01.S08.4	3.125 X 7.5 TPI	X 1.5 NH
01.S08.5	3.030 X 8 TPI	X 1.5 NH
01.S08.6	3.234 X 6 TPI	X 1.5 NH
01.S08.7	3.125 X 5 TPI	X 1.5 NPSH
01.S08.8	3.078 X 8 TPI	X 1.5 NH
01.S08.9	3.340 X 6 TPI	X 1.5 NH
01.S08.11	3.230 X 5 TPI	X 1.5 NPSH
01.S08.12	3.031 X 7 TPI	X 1.5 NPSH
01.S08.13	3.165 X 7.5TPI	X 1.5 NH
01.S08.20	3.00 X 8 TPI	X 1.5 NPSH
01.S08.21	2.990 X 8 TPI	X 1.5 NPSH
01.S08.22	3.250 X 6 TPI	X 1.5 NPSH
01.S08.23	3.031 X 7 TPI	X 1.5 NPSH
01.S08.24	3.093 X 6 TPI	X 1.5 NH
01.S08.26	3.062 X 8 TPI	X 1.5 NH
01.S08.27	3.078 X 6 TPI	X 1.5 NH
01.S08.28	3.156 X 6 TPI	X 1.5 NH
01.S08.29	3.062 X 6 TPI	X 1.5 NPSH
01.S08.30	2.841 X 8 TPI	X 1.5 NPSH
01.S08.31	3.077 X 7 TPI	X 1.5 NH
01.S08.33	3.125 X 6 TPI	X 1.5 NPSH
01.S08.35	3.250 X 5 TPI	X 1.5 NPSH

REVISIONS				
REV	DESCRIPTION	DATE	DRAWN BY	APPROVED

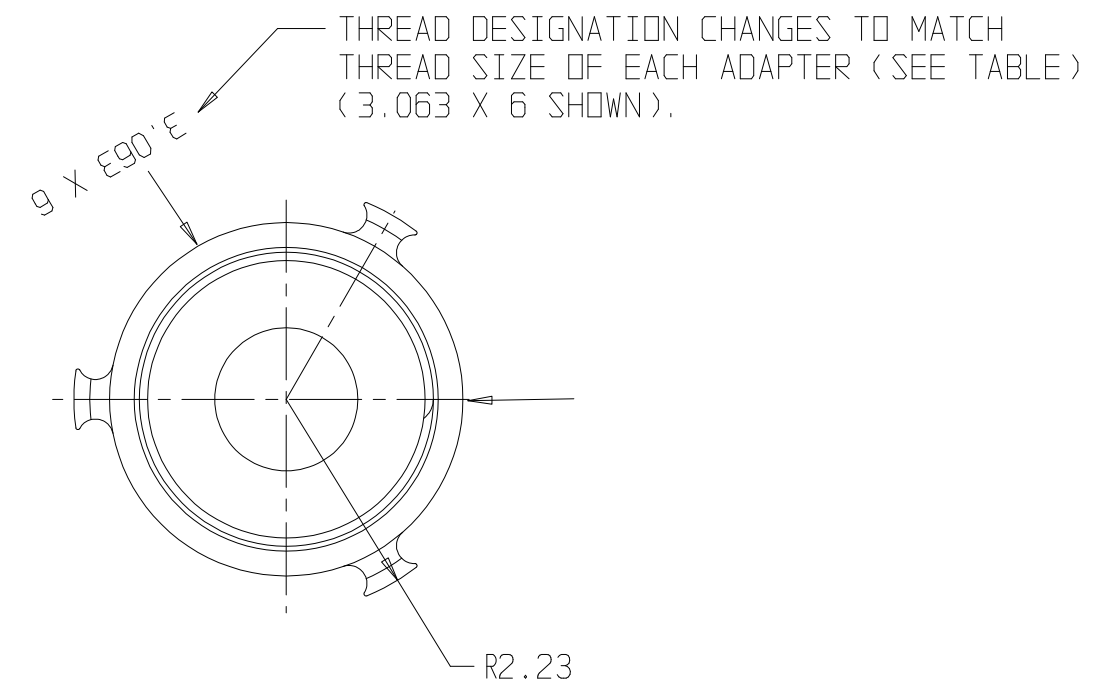
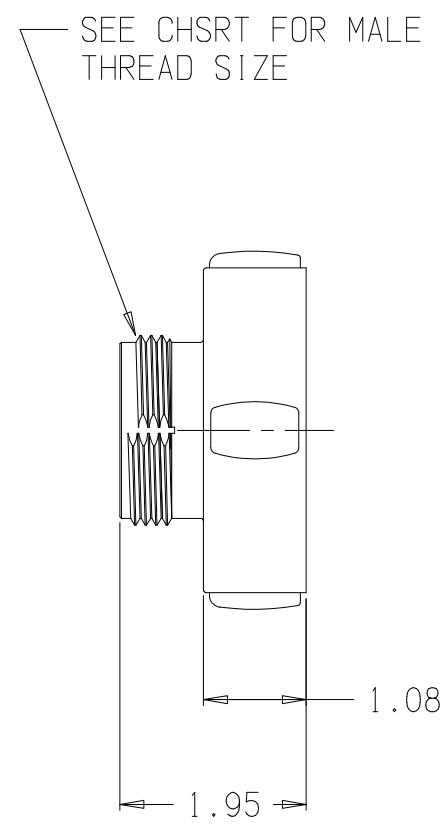

NOTES:
1) CHROME PLATED

 EMERGENCY PRODUCTS, LLC	SPCL. THD. DISCH. REDUCER		
	<small>REPORT ERRORS & CHANGES REMOVE ALL SHARP EDGES UNLESS OTHERWISE SPECIFIED ALL DIMENSIONS ARE IN INCHES</small>	<small>STANDARD TOLERANCES:</small> <small>DECIMALS .XX ± .030 .XXX ± .015</small>	<small>ANGLES ± 1/2°</small>
<small>COPYRIGHT © DRAWING NOT TO BE REPRODUCED OR USED TO MAKE OTHER DRAWINGS OR MACHINERY</small>	<small>SIZE B</small>	<small>DWG NO. 01.S08.XXPC</small>	<small>REV</small>
<small>DRAWN BY MS CHECKED BY MS</small>	<small>DATE 10/24/2003</small>	<small>SCALE 1:2</small>	<small>SHEET 1 OF 2</small>