

NOTES:

- 1. MATERIAL - BRASS ALLOY
- 2. CHROME PLATED

REVISIONS				
ZONE	REV	DESCRIPTION	DATE	APPROVED

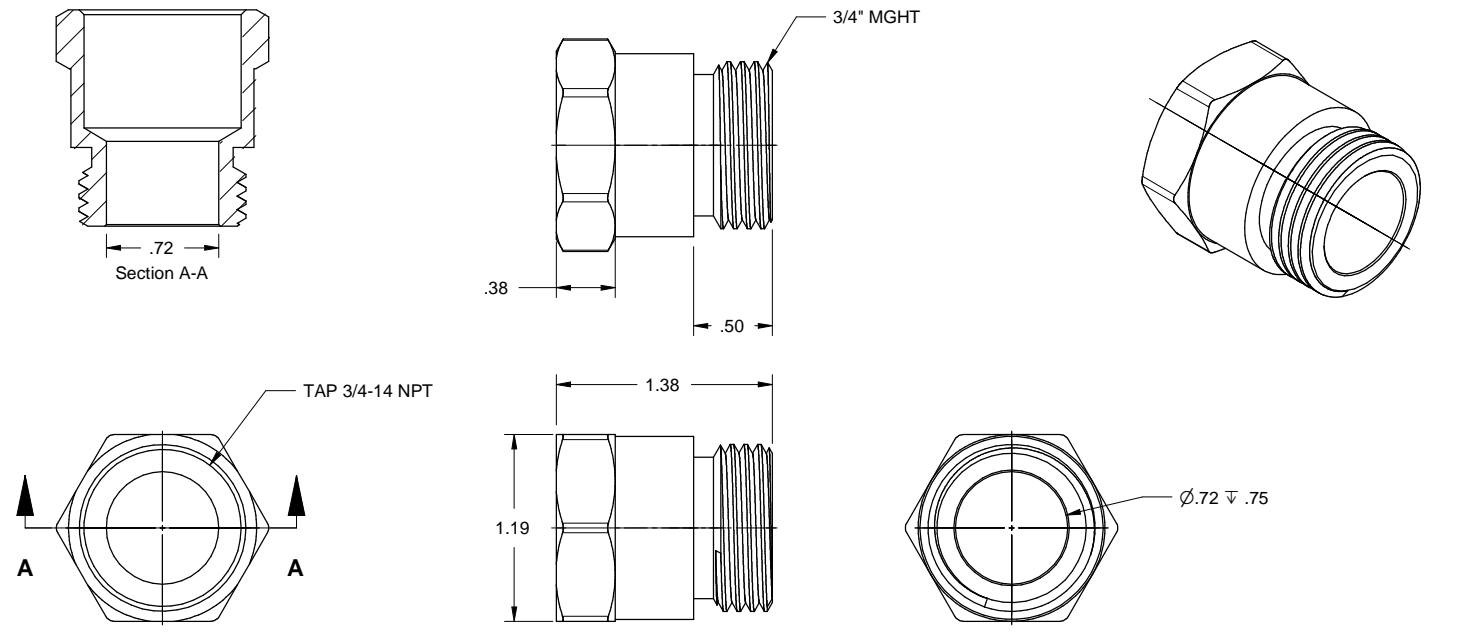

REMOVE ALL SHARP EDGES ALL DIMENSIONS ARE INCHES STANDARD TOLERANCES: .XX +/- .015 .XXX +/- .005 ANGLES +/- .5°	DRAWN MS	DATE 05/04/2010	TRIDENT EMERGENCY PRODUCTS, LLC <i>"Tomorrow's Ideas Delivered Today"</i>			
	CHECKED					ADAPTER, .75 FNPT X .75 MGHT
	QA		SIZE A	FSCM NO.	DWG NO. 01.141.0PC	
COPYRIGHT © DRAWING NOT TO BE REPRODUCED OR USED TO MAKE OTHER DRAWINGS OR MACHINERY	MFG		SCALE 1:1		SHEET 1:1	

