

PART NO.	THREAD FORM
01.S31.0	3.125 x 5 TPI
01.S31.1	3.078 X 6 TPI
01.S31.2	3.00 X 8 TPI
01.S31.3	3.00 X 8 TPI
01.S31.4	3.063 X 6 TPI
01.S31.5	3.156 X 6 TPI
01.S31.6	3.078 X 8 TPI
01.S31.7	3.055 X 6 TPI
01.S31.8	2.843 X 8 TPI
01.S31.9	3.125 X 7.5 TPI
01.S31.10	3.328 X 8 TPI
01.S31.11	3.125 X 6 TPI
01.S31.12	3.040 X 8 TPI
01.S31.13	3.030 X 8 TPI
01.S31.14	3.06 X 7 TPI
01.S31.15	3.234 x 6 TPI
01.S31.16	3.175 x 6 TPI
01.S31.17	3.031 X 7 TPI
01.S31.18	2.990 X 8 TPI
01.S31.19	3.250 X 5 TPI
01.S31.20	3.230 x 5 TPI
01.S31.21	3.250 x 6 TPI

REVISIONS				
REV	DESCRIPTION	DATE	DRAWN BY	APPROVED

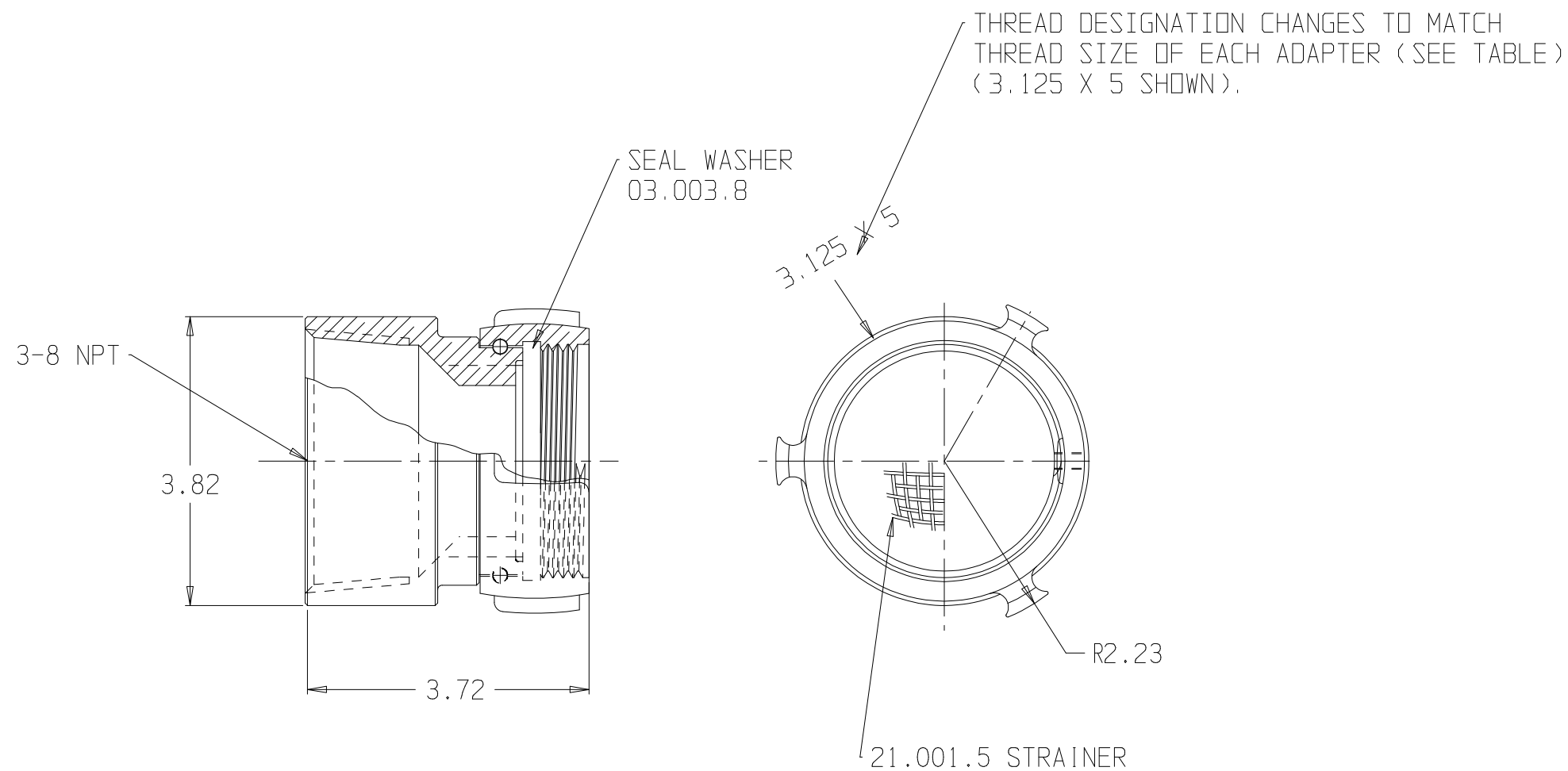

NOTES:  
1) CHROME PLATED

	SPCL. THD 3x2.5 SUCT. ADPTR.		
	REPORT ERRORS & CHANGES REMOVE ALL SHARP EDGES UNLESS OTHERWISE SPECIFIED ALL DIMENSIONS ARE IN INCHES	STANDARD TOLERANCES: DECIMALS .XX ± .030 .XXX ± .015	ANGLES ± 1/2°
COPYRIGHT © DRAWING NOT TO BE REPRODUCED OR USED TO MAKE OTHER DRAWINGS OR MACHINERY	SIZE B	DWG NO. 01.S31.XXPC	REV .
DRAWN BY MS CHECKED BY MS	DATE 02/17/2005	SCALE 1:2	SHEET 1 OF 1