

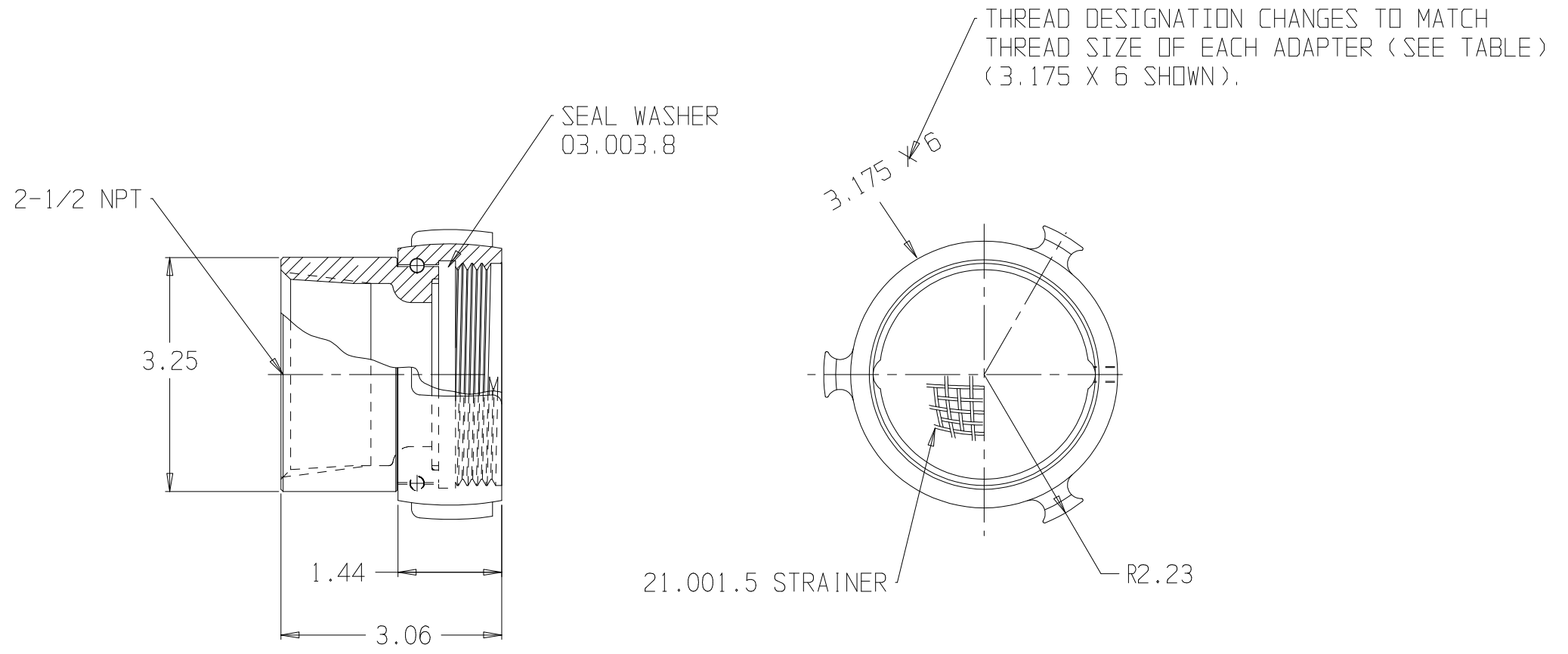

PART NO.	THREAD FORM
01.S30.0	3.175 x 6 TPI
01.S30.1	3.078 X 6 TPI
01.S30.2	3.00 X 8 TPI
01.S30.3	3.00 X 8 TPI
01.S30.4	3.063 X 6 TPI
01.S30.5	3.156 X 6 TPI
01.S30.6	3.078 X 8 TPI
01.S30.7	3.055 X 6 TPI
01.S30.8	2.843 X 8 TPI
01.S30.9	3.125 X 7.5 TPI
01.S30.10	3.328 X 8 TPI
01.S30.11	3.125 X 6 TPI
01.S30.12	3.040 X 8 TPI
01.S30.13	3.030 X 8 TPI
01.S30.14	3.06 X 7 TPI
01.S30.15	3.234 x 6 TPI
01.S30.16	3.250 X 6 TPI
01.S30.17	3.125 X 5 TPI
01.S30.18	3.093 X 8 TPI
01.S30.19	3.187 X 6 TPI
01.S30.20	2.990 X 8 TPI
01.S30.21	2.968 X 8 TPI
01.S30.22	3.062 X 8 TPI
01.S30.23	3.077 X 7 TPI
01.S30.24	3.230 X 5 TPI
01.S30.25	3.250 X 5 TPI
01.S30.26	3.031 X 7 TPI

REVISIONS				
REV	DESCRIPTION	DATE	DRAWN BY	APPROVED



NOTES:

1) CHROME PLATED

 EMERGENCY PRODUCTS, LLC	SPCL. THD 2.5" SUCT. ADPTR.		
	<small>REPORT ERRORS & CHANGES REMOVE ALL SHARP EDGES UNLESS OTHERWISE SPECIFIED ALL DIMENSIONS ARE IN INCHES</small>	<small>STANDARD TOLERANCES:</small> <small>DECIMALS .XX ± .030 .XXX ± .015</small>	<small>ANGLES ± 1/2°</small>
<small>COPYRIGHT © DRAWING NOT TO BE REPRODUCED OR USED TO MAKE OTHER DRAWINGS OR MACHINERY</small>	<small>SIZE B</small>	<small>DWG NO. 01.S30.XXPC</small>	<small>REV</small>
<small>DRAWN BY MS CHECKED BY MS</small>	<small>DATE 07/22/2004</small>	<small>SCALE 1:2</small>	<small>SHEET 1 OF 1</small>