

REVISIONS				
REV	DESCRIPTION	DATE	DRAWN BY	APPROVED

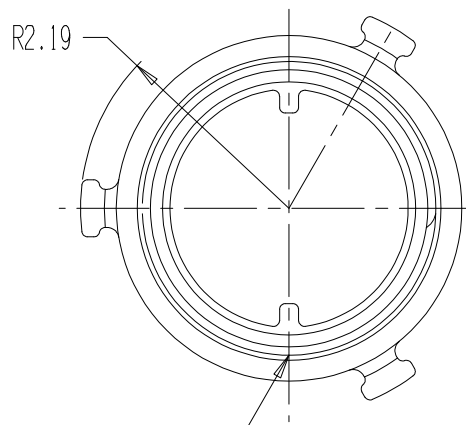
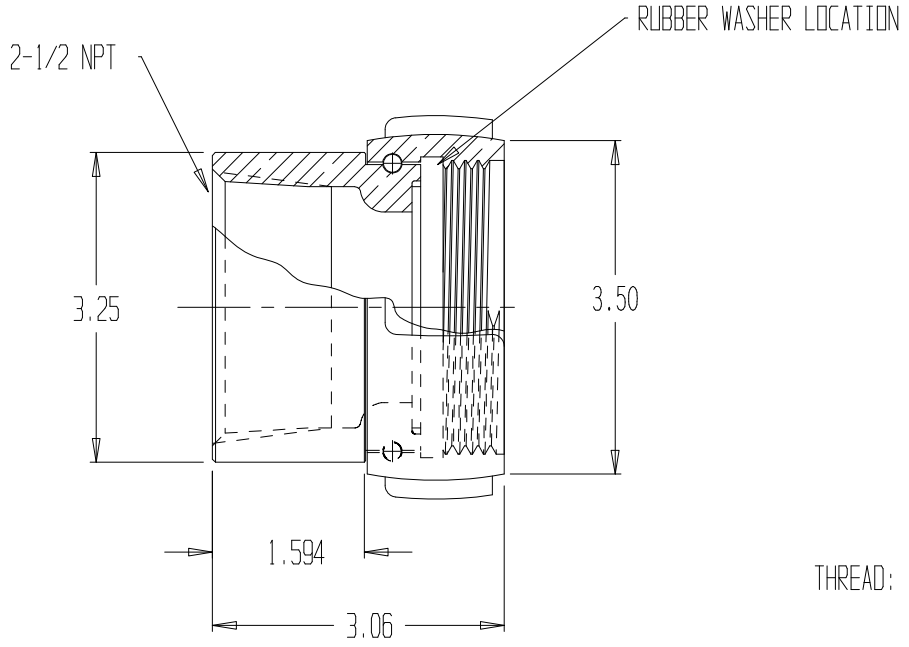

THREAD: 2.5-7.5 NH (FIRE HOSE THD)

NOTES:

- 1) CHROME PLATED
- 2) MATERIAL: BRASS
- 3) RUBBER WASHER INCLUDED
- 4) BALL MATERIAL: BRASS



ADAPTER, 2.5FNPT X 2.5FNH

REPORT ERRORS & CHANGES
 REMOVE ALL SHARP EDGES
 UNLESS OTHERWISE SPECIFIED
 ALL DIMENSIONS ARE IN INCHES

STANDARD TOLERANCES:

DECIMALS	ANGLES
.XX ± .030	± 1/2°
.XXX ± .015	

DRAWING NOT TO BE REPRODUCED OR USED TO MAKE OTHER DRAWINGS OR MACHINERY		COPYRIGHT ©	SIZE A	DWG NO.	01.030.5PC	REV
DRAWN BY	MS	DATE	04/01/2002	SCALE	1:2	SHEET 1 OF 1
CHECKED BY	MS					