

REVISIONS				
REV	DESCRIPTION	DATE	DRAWN BY	APPROVED

THREAD: 2.5-7.5 NH (FIRE HOSE THD)

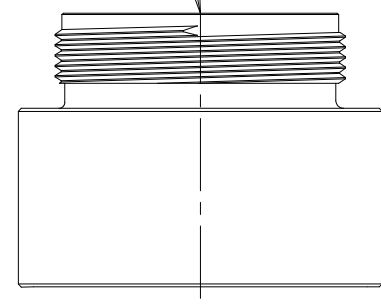
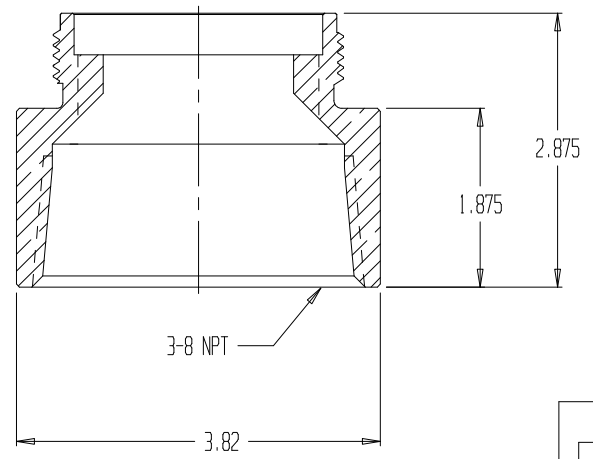

- NOTES:
- 1) MATERIAL: BRASS
 - 2) CHROME PLATED
 - 3) STRAINER INCLUDED, NOT SHOWN

SECTION A-A



ADAPTER-2.5 MNH X 3 FNPT

REPORT ERRORS & CHANGES
 REMOVE ALL SHARP EDGES
 UNLESS OTHERWISE SPECIFIED
 ALL DIMENSIONS ARE IN INCHES

STANDARD TOLERANCES:

DECIMALS	ANGLES
.XX ± .030	± 1/2°
.XXX ± .015	

COPYRIGHT © DRAWING NOT TO BE REPRODUCED OR USED TO MAKE OTHER DRAWINGS OR MACHINERY		SIZE A	DWG NO.	01.038.5PC	REV
DRAWN BY MS	CHECKED BY MS	DATE 05/24/2002	SCALE 1:2	SHEET 1 OF 1	