

REVISIONS				
REV	DESCRIPTION	DATE	DRAWN BY	APPROVED

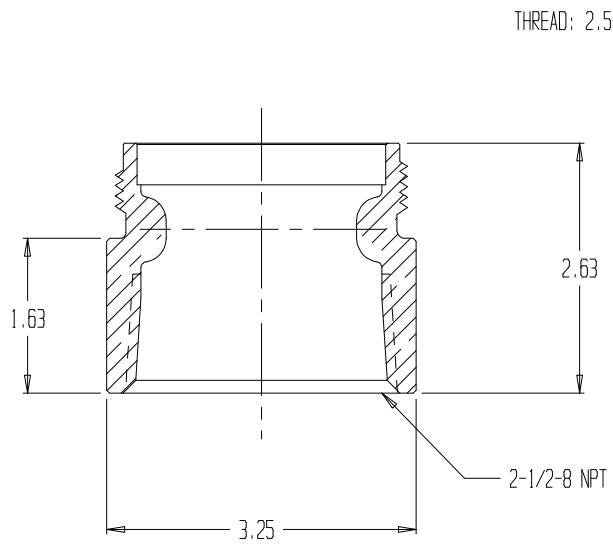

THREAD: 2.5-7.5 NH (FIRE HOSE THD)

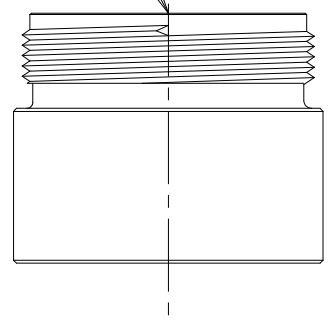

- NOTES:
 1) MATERIAL: BRASS
 3) CHROME PLATED

SECTION A-A



ADAPTER-2.5MNST X 2.5FNPT

REPORT ERRORS & CHANGES
 REMOVE ALL SHARP EDGES
 UNLESS OTHERWISE SPECIFIED
 ALL DIMENSIONS ARE IN INCHES

STANDARD TOLERANCES:

DECIMALS	ANGLES
.XX ± .030	± 1/2°
.XXX ± .015	

DRAWING NOT TO BE REPRODUCED OR USED TO MAKE OTHER DRAWINGS OR MACHINERY		COPYRIGHT ©		SIZE	DWG NO.	REV
DRAWN BY	001	DATE	08/23/2000	A	01.001.0PC	
CHECKED BY	001	SCALE	1:2			SHEET 1 OF 1